

# DT4-B261

パーツブック

PARTS BOOK

TEILEKATALOG

LIVRE DES PIECES

LIBRO DE REFERENCIA DE PIEZAS

箱型1本針二重環縫ミシン

箱型2本針二重環縫ミシン

FLAT BED SINGLE NEEDLE DOUBLE CHAIN STITCHER

FLAT BED TWIN NEEDLE DOUBLE CHAIN STITCHER

EINNADEL-FLACHBETT-DOPPELKETTENSTICHMASCHINE

ZWEINADEL-FLACHBETT-DOPPELKETTENSTICHMASCHINE

MACHINE POINT DE CHAINETTE A PLATEAU - 1 AIGUILLE

MACHINE POINT DE CHAINETTE A PLATEAU - 2 AIGUILLES

RECUBRIDORA PLANA, UNA AGUJA

RECUBRIDORA PLANA, DOS AGUJAS



P261201

brother®

## パーツブックご利用に際して

1. この本は、この本の表紙(正誤表の挿入されている場合は正誤表)に記載されているものと同じプレートが取り付けられているミシンのためのものです。
2. この本は、1999年1月のデータに基づいて作成されたものです
3. 部品は予告なしに設計変更される場合があります。
4. 組単位で補給する部品は、[ ] 破線で示しております。
5. 部品コード欄が※となっている場合は、仕様別部品一覧表(49ページ)でお調べ下さい。

## 目 次

A. 主体関係 .....	1
B. 上軸・針棒関係 .....	11
C. 針冷却関係 .....	17
D. ラッパー関係 .....	17
E. 押エ関係 .....	19
F. 送り関係 .....	25
G. プーラ装置関係 .....	29
H. 下軸関係 .....	33
J. ルーパー関係 .....	35
K. 給油潤滑関係 .....	37
L. 糸調子関係 .....	39
Z. 付属品関係 .....	45
ゲージ部品一覧表 .....	49
索引 .....	53

## Notes for using this parts book

1. This book is applicable to sewing machines which have the same plate number as shown on the cover of this book (or correction sheet).
2. This book was prepared based on information available in January 1999.
3. Parts are subject to changes in design without prior notice.
4. Parts supplied as complete assemblies are circled by a dotted line [-----].
5. If the symbol ※ is found in the "Parts No." column, refer to the different parts list on page 49.

## CONTENTS

A. Machine body .....	1
B. Upper shaft and needle bar mechanism .....	11
C. Needle cooler .....	17
D. Lapper mechanism .....	17
E. Presser foot mechanism .....	19
F. Feed mechanism .....	25
G. Puller device mechanism .....	29
H. Lower shaft mechanism .....	33
J. Looper mechanism .....	35
K. Lubrication .....	37
L. Thread tension .....	39
Z. Accessories .....	45
GAUGE PARTS LIST .....	49
INDEX .....	53

## Hinweise zur Verwendung dieser Teileliste

1. Dieses Buch bezieht sich auf die Nähmaschinen mit derselben Kennungsnummer wie auf diesem Buchumschlag (oder auf dem Korrekturblatt).
2. Dieses Buch basiert auf den Informationen vom Januar 1999.
3. Modelländerungen sind vorbehalten.
4. Die Teile, die als kompletter Satz geliefert werden, sind mit einer [-----] gestrichelten Linie umrandet.
5. Dieses Zeichen ※ in der Spalte "Parts No. (Teil-nummer)" verweist auf die Gesonderte Stückliste auf Seite 49.

## INHALTSVERZEICHNIS

A. Maschinengehäuse .....	1
B. Obere Welle und Nadelstangenvorrichtung .....	11
C. Nadelkühlungsvorrichtung ...	17
D. Falz-mechanismus .....	17
E. Stoffdrückerfuß .....	19
F. Transportvorrichtung .....	25
G. Ziehvorrichtung .....	29
H. Untere Welle .....	33
J. Greifer .....	35
K. Schmierung .....	37
L. Fadenspannung .....	39
Z. Zubehör .....	45
LEHRENLISTE .....	49
VERZEICHNIS .....	53

## Notes sur l'utilisation de ce manuel de pièces détachées

1. Ce manuel est destiné aux machines à coudre ayant le même numéro de plaque montré sur la couverture de ce manuel (ou sur la feuille de corrections).
2. Ce manuel a été fait d'après les renseignements valables au mois de Janvier 1999.
3. Les pièces peuvent être sujettes à des modifications sans préavis.
4. Les pièces fournies en tant qu'assemblages complets sont encadrées avec un trait pointillé [ ] .
5. Si le symbole ※ se trouve dans la colonne "Parts No. (N° de pièce)" veuillez la vous référer à la liste de pièces annexe page 49.

## TABLE DES MATIERES

A. Corps de la machine	1
B. Mécanisme de arbre supérieur et barra à aiguille	11
C. Mécanisme du refroidisseur d'aiguille	17
D. Mécanisme à rabat	17
E. Mécanisme de pied presseur	19
F. Mécanisme de l'entraînement	25
G. Mécanisme due puller	29
H. Mécanisme de l'arbre inférieur	33
J. Mécanisme des griffes	35
K. Lubrification	37
L. Tension du fil	39
Z. Accessoires	45
LISTE DES PIECES D'ECARTEMENT	49
INDEX	53

## Notas para usar este Manual de Piezas

1. Este libro sirve para todas las máquinas de coser que llevan la misma placa de identificación que la que se puede ver en la tapa de este libro (o en la hoja de erratas).
2. Este libro ha sido compilado basándose en los datos de que se disponía en enero 1999.
3. Las piezas quedan sujetas a cambios de diseño sin aviso previo.
4. Las piezas suministradas como conjuntos completos se enmarcan con una línea punteada [ ] .
5. De haber un símbolo ※ junto al "Parts No. (Número de Pieza)", habrá que mirar la lista de piezas separada de la página 49.

## INDICE

A. Cuerpo de la máquina	1
B. Mecanismo del eje superior y la barra de aguaja	11
C. Mecanismo del enfriador de aguja	17
D. Mecanismo de solapado	17
E. Mecanismo de la prensa tela	19
F. Mecanismo de la alimentación	25
G. Mecanismo del dispositivo de arrastre	29
H. Mecanismo del eje inferior	33
J. Mecanismo del presilladora	35
K. Lubricación	37
L. Tensión del hilo	39
Z. Accesorios	45
LISTA DE PIEZAS DE CALIBRADORES	49
INDICE	53

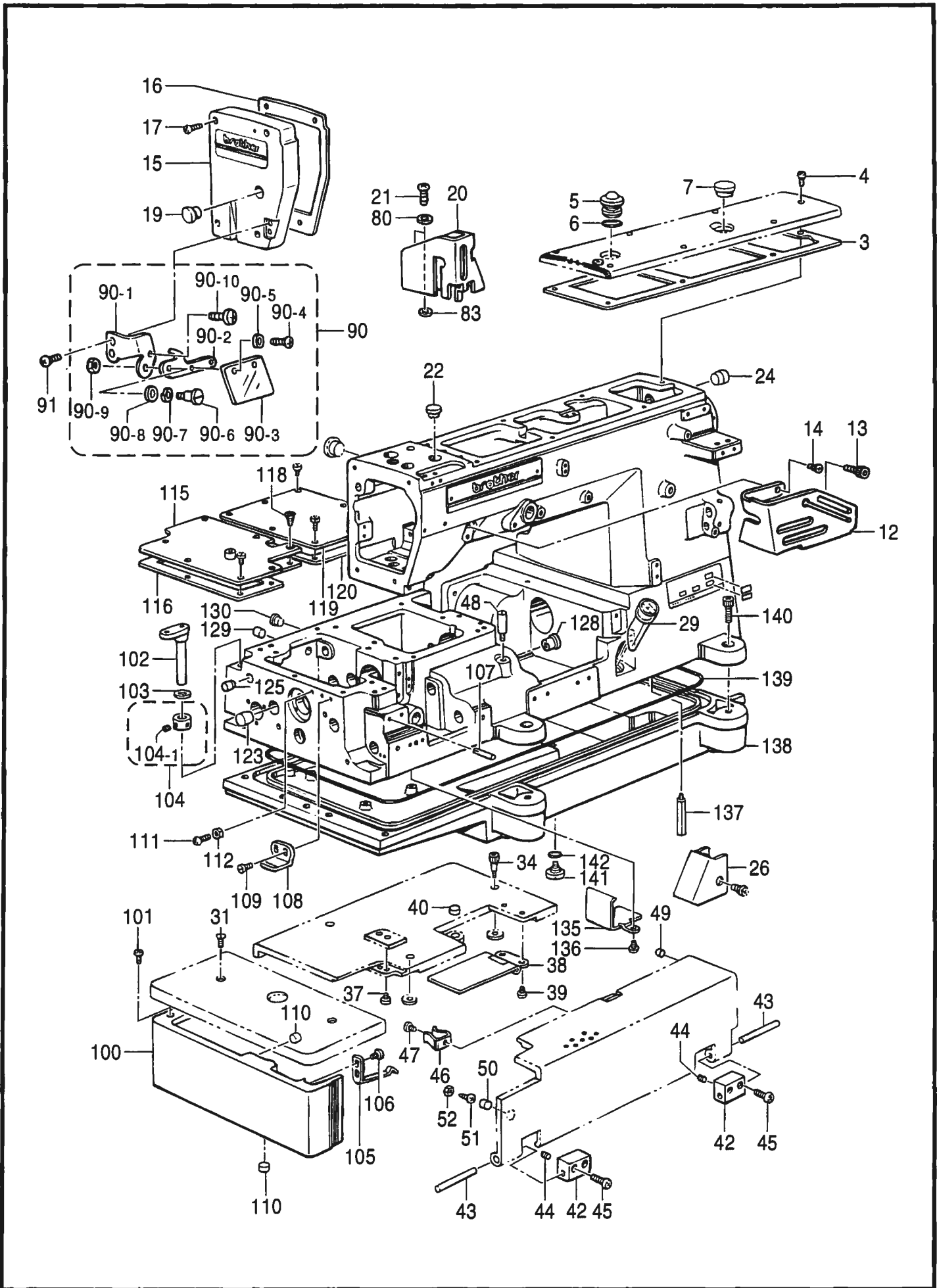

A. 主体関係 / Machine body / Maschinengehäuse / Corps de la machine / Cuerpo de la máquina

REF.NO.	CODE	Q'TY	ヒンメイ	NAME OF PARTS	RM
3	S08628000	1	ウワフタパツキン	TOP COVER PACKING	
4	062681012	7	ナベコ437-40X10	SCREW, PAN SM4.37-40X10	
5	S02606000	1	ユリヨウケイマド	OIL GAUGE WINDOW	
6	081014670	1	OリングPW14	O RING, PW14	
7	159150009	1	ゴムセン20.5	RUBBER CAP, 20.5	
12	S40532101	1	ハリイトクリカパー	NEEDLE THREAD TAKE-UP COVER	
13	018060822	1	アナボルト6X8	BOLT, SOCKET M6X8	
14	S10774001	1	ナベコ437-40X7	SCREW, PAN M4.37-40X7	
15	S28810051	1	メンイタ	FACE PLATE	
16	S08631000	1	メンイタハツキン	FACE PLATE PACKING	
17	062681612	4	ナベコ437-40X16	SCREW, PAN SM4.37-40X16	
19	117934009	1	ゴムセン13.5	RUBBER CAP, 13.5	
20	S28809201	1	ハリボウテンピンカバー	NEEDLE BAR TAKE-UP COVER	
21	062681012	2	ナベコ437-40X10	SCREW, PAN SM4.37-40X10	
22	104449009	1	ゴムセン15.5	RUBBER CAP, 15.5	
24	S00313009	1	ゴムセン16.8	RUBBER CAP, 16.8	
26	S08633101	1	シタイトカバー	BOBBIN THREAD COVER	
29	148084001	1	オイルゲージマド	OIL GAUGE WINDOW	
31	100032004	2	サラネジ4.37	SCREW, FLAT SM4.37	
34	S09123101	3	アナボルト4.37X15	BOLT, SOCKET M4.37X15	
37	123185001	2	マルヒラネジ3.57X4.5	SCREW, OVAL M3.57X4.5	
38	S08642001	1	シタイトテンピンカバークミ	LOOPER THREAD TAKE-UP COVER ASSY	
39	123185001	2	マルヒラネジ3.57X4.5	SCREW, OVAL M3.57X4.5	
40	S08646100	1	マグネット	MAGNET	
42	S08651001	2	マエカバーササエ	FRONT COVER SUPPORT	
43	S08652000	2	マエカバーササエジク	FRONT COVER SUPPORT SHAFT	
44	153675001	2	アナトメネジ4.37	SET SCREW, SOCKET SM4.37	
45	060681612	4	バインド437-40X16	SCREW, BIND SM4.37-40X16	
46	114985001	1	ベツトカバートメバネ	SPRING, PLATE	
47	062680612	1	ナベコ4.37-40X6	SCREW, PAN SM4.37-40X6	
48	S08653001	1	バネウケネジ	SCREW	
49	142274009	2	ゴムセン4.2	RUBBER CAP, 4.2	
50	146586009	1	ゴムセン11	RUBBER CAP, 11	
51	062681412	1	ナベコ437-40X14	SCREW, PAN SM4.37-40X14	
52	105234003	1	ナツト4.37	NUT, SM4.37	
80	100645003	2	ザガネ	WASHER	
83	025680133	2	ヒラザガネシヨウ4.37	WASHER, PLAIN S 4.37	
90	S28802001	1	アイガードクミ	EYE GUARD ASSY	
90-1	S28803001	1	アイガードドダイ	EYE GUARD BASE	
90-2	S28804001	1	アイガードトリツケイタ	EYE GUARD SETTING PLATE	
90-3	S00075000	1	アイガード	EYE GUARD	
90-4	062660512	2	ナベコネジ318-40X5	SCREW, PAN SM3.18-40X5	
90-5	025030232	2	ヒラザガネチユウ3	WASHER, PLAIN M 3	
90-6	S07317001	1	ダンネジ3.57	SHOULDER SCREW, SM3.57	
90-7	028050246	1	バネザガネ2-5	WASHER, SPRING 2-5	
90-8	025050232	1	ヒラザガネチユウ5	WASHER, PLAIN M 5	
90-9	106129001	1	ナツト3.57	NUT, SM3.57	
90-10	060670512	1	バインド357-40X5	SCREW, BIND SM3.57-40X5	
91	060680712	2	バインド437-40X7	SCREW, BIND SM4.37-40X7	
100	S08665001	1	ヨコカバー	SIDE COVER	
101	062680812	2	ナベコ437-40X8	SCREW, PAN SM4.37-40X8	
102	S00017001	1	クロスプレートササエジク	CLOTH PLATE SUPPORT SHAFT	
103	141183000	1	クロスプレートシート	CLOTH PLATE SHEET	
104	183893001	1	セツトカラークミ	SET SCREW COLLAR ASSY	
104-1	101706001	2	トメネジ6.35	SET SCREW, SM6.35	
105	S08667001	1	ヨコカバートメイタバネ	PLATE SPRING	
106	060680712	2	バインド437-40X7	SCREW, BIND SM4.37-40X7	
107	140063001	1	ミゾツキピン	DOWEL PIN	
108	S08668001	1	ヨコカバーガイド	SIDE COVER GUIDE	

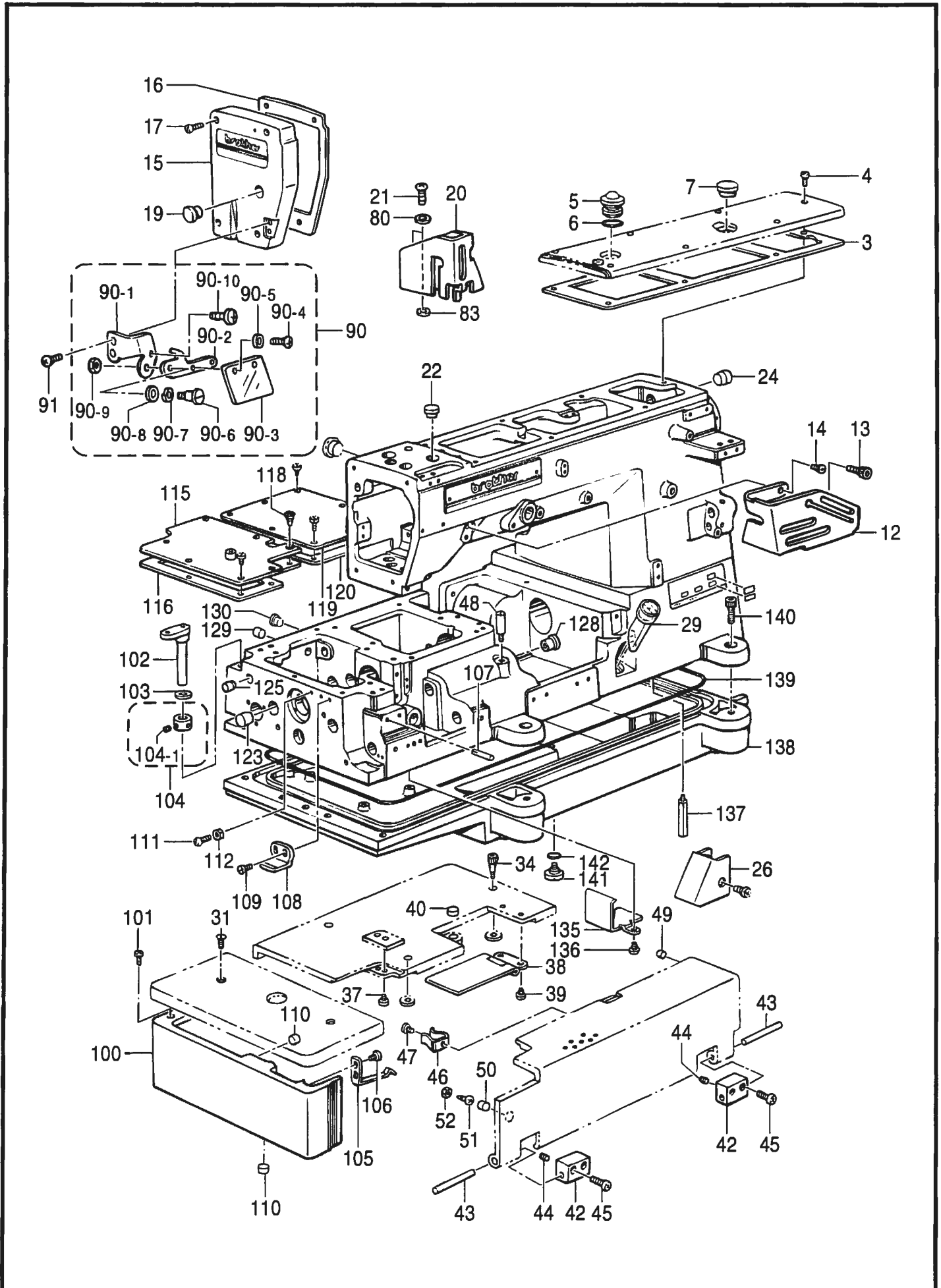

## A. 主体関係 / Machine body / Maschinengehäuse / Corps de la machine / Cuerpo de la máquina

REF.NO.	CODE	Q'TY	ヒンメイ	NAME OF PARTS	RM
109	107407003	2	シメネジ4.37	SCREW, SM4.37X9	
110	146586009	2	ゴムセン11	RUBBER CAP, 11	
111	062681012	1	ナヘコ437-40X10	SCREW, PAN SM4.37-40X10	
112	105234003	1	ナツト4.37	NUT, SM4.37	
115	S40533001	1	オクリキコウカバー	FEED MECHANISM COVER	
116	S08670000	1	オクリキコウカバーパツキン	FEED MECHANISM COVER PACKING	
118	151267001	1	サラネジ4.37	SCREW, FLAT SM4.37	
119	S08671101	1	ヘッドウワカバー	BED UPPER COVER	
120	S08672000	1	ヘッドウワカバーパツキン	BED UPPER COVER PACKING	
123	S00313009	1	ゴムセン16.8	RUBBER CAP, 16.8	
125	146315009	1	ゴムセン10.7	RUBBER CAP, 10.7	
128	S08673000	1	ゴムセン14	RUBBER CAP, 14	
129	146586009	1	ゴムセン11	RUBBER CAP, 11	
130	104450109	1	ゴムセン8	RUBBER CAP, 8	
135	146457001	1	シキリイタ	OIL STOPPER PLATE	
136	062670612	2	ナベコ357-40X6	SCREW, PAN SM3.57-40X6	
137	151059001	4	ホнтаイシチュウ	LEG, MACHINE BODY	
138	S08674000	1	アブラウケ	OIL RESERVOIR	
139	S08675000	1	Oリング	O RING	
140	018081622	5	アナボルト8X16	BOLT, SOCKET M8X16	
141	110641002	1	ダンネジ9.52	STUD SCREW, SM9.52	
142	109203001	1	Oリング	O RING	



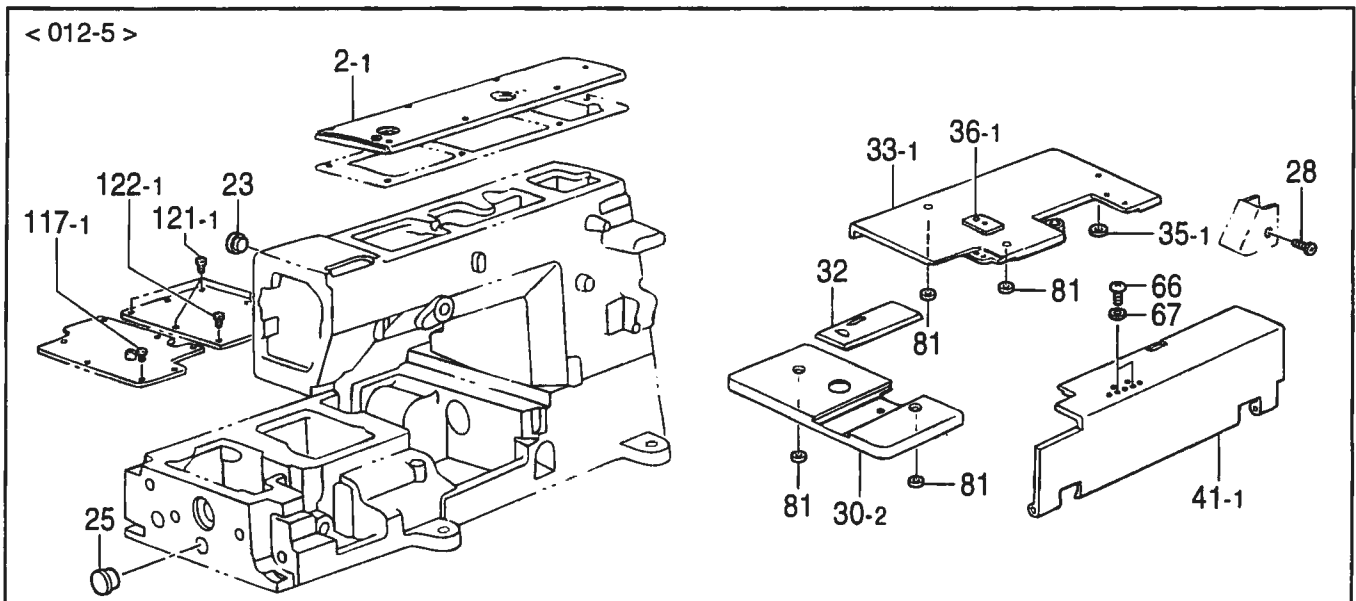
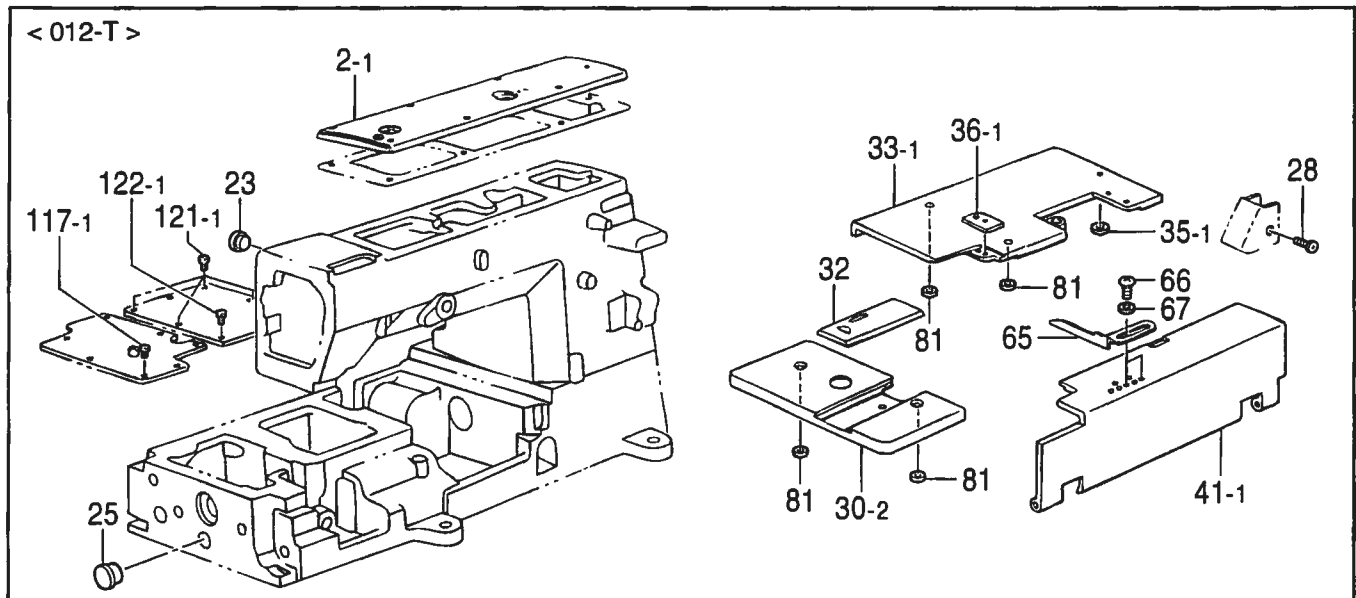
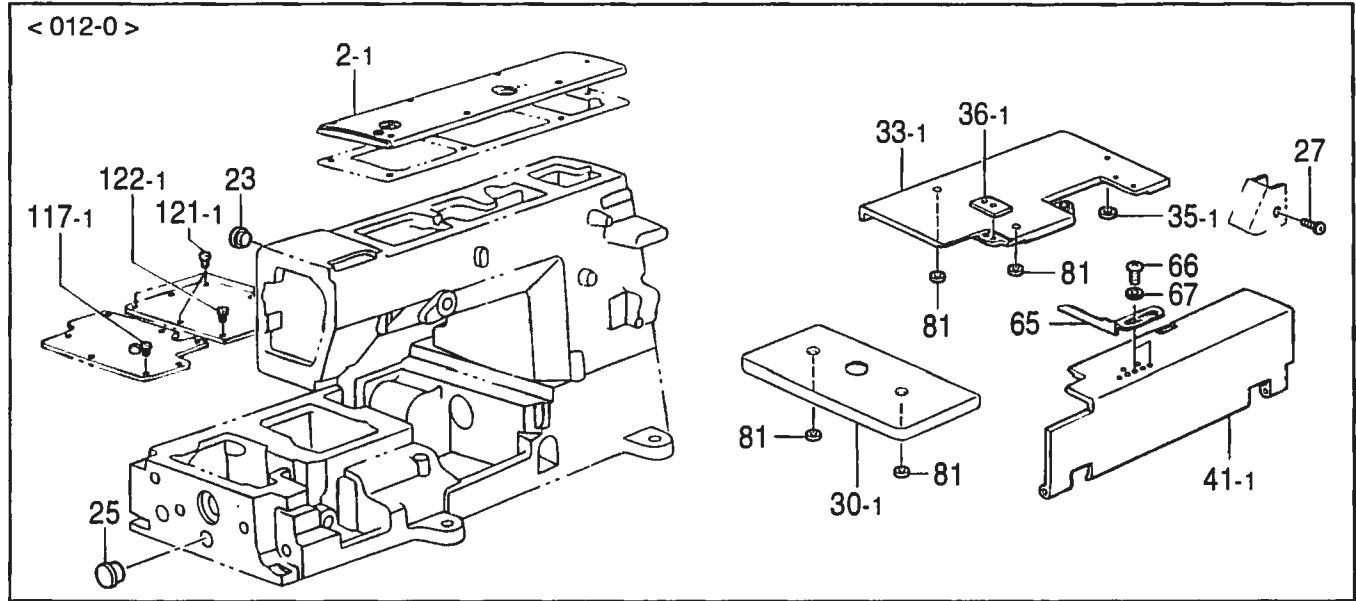

A. 主体関係 / Machine body / Maschinengehäuse / Corps de la machine / Cuerpo de la máquina

REF.NO.	CODE	Q'TY	ヒンメイ	NAME OF PARTS	RM
			<b>&lt;012-0&gt;</b>	<b>&lt;012-0&gt;</b>	
2-1	S08627001	1	ウワフタ	TOP COVER	
23	108520009	1	ゴムセン19.8	RUBBER CAP, 19.8	
25	158437009	1	ゴムセン10	RUBBER CAP, 10	
27	062680812	1	ナヘコ437-40X8	SCREW, PAN SM4.37-40X8	
30-1	S08634151	1	クロスプレートL	CLOTH PLATE (L)	
33-1	S08637001	1	クロスプレートR	CLOTH PLATE (R)	
35-1	S08639000	1	クロスプレートハツキン	CLOTH PLATE PACKING	
36-1	S08640001	1	クロスプレートホジヨイタ	SUB-CLOTH PLATE	
41-1	S08647101	1	マエカバー	FRONT COVER	
65	S40535001	1	ヌノガイド	CLOTH GUIDE	
66	062710812	2	ナベコ476-32X8	SCREW, PAN SM4.76-32X8	
67	146354001	2	ザガネ	WASHER, PLAIN 5	
81	S34200000	4	ソレノイドクツシヨン	SOLENOID CUSHION	
117-1	107407003	6	シメネジ4.37	SCREW, SM4.37X9	
121-1	107407003	4	シメネジ4.37	SCREW, SM4.37X9	
122-1	117516001	2	ボルト4.37	BOLT, M4.37	
			<b>&lt;012-T&gt;</b>	<b>&lt;012-T&gt;</b>	
2-1	S08627001	1	ウワフタ	TOP COVER	
23	108520009	1	ゴムセン19.8	RUBBER CAP, 19.8	
25	158437009	1	ゴムセン10	RUBBER CAP, 10	
28	062681012	1	ナベコ437-40X10	SCREW, PAN SM4.37-40X10	
30-2	S40960051	1	クロスプレートL	CLOTH PLATE (L)	
32	S40961001	1	スベリイタ	SLIDE PLATE	
33-1	S08637001	1	クロスプレートR	CLOTH PLATE (R)	
35-1	S08639000	1	クロスプレートハツキン	CLOTH PLATE PACKING	
36-1	S08640001	1	クロスプレートホジヨイタ	SUB-CLOTH PLATE	
41-1	S08647101	1	マエカバー	FRONT COVER	
65	S40535001	1	ヌノガイド	CLOTH GUIDE	
66	062710812	2	ナベコ476-32X8	SCREW, PAN SM4.76-32X8	
67	146354001	2	ザガネ	WASHER, PLAIN 5	
81	S34200000	4	ソレノイドクツシヨン	SOLENOID CUSHION	
117-1	107407003	6	シメネジ4.37	SCREW, SM4.37X9	
121-1	107407003	4	シメネジ4.37	SCREW, SM4.37X9	
122-1	117516001	2	ボルト4.37	BOLT, M4.37	
			<b>&lt;012-5&gt;</b>	<b>&lt;012-5&gt;</b>	
2-1	S08627001	1	ウワフタ	TOP COVER	
23	108520009	1	ゴムセン19.8	RUBBER CAP, 19.8	
25	158437009	1	ゴムセン10	RUBBER CAP, 10	
28	062681012	1	ナベコ437-40X10	SCREW, PAN SM4.37-40X10	
30-2	S40960051	1	クロスプレートL	CLOTH PLATE (L)	
32	S40961001	1	スベリイタ	SLIDE PLATE	
33-1	S08637001	1	クロスプレートR	CLOTH PLATE (R)	
35-1	S08639000	1	クロスプレートハツキン	CLOTH PLATE PACKING	
36-1	S08640001	1	クロスプレートホジヨイタ	SUB-CLOTH PLATE	
41-1	S08647101	1	マエカバー	FRONT COVER	
66	062710812	2	ナベコ476-32X8	SCREW, PAN SM4.76-32X8	
67	146354001	2	ザガネ	WASHER, PLAIN 5	
81	S34200000	4	ソレノイドクツシヨン	SOLENOID CUSHION	
117-1	107407003	6	シメネジ4.37	SCREW, SM4.37X9	
121-1	107407003	4	シメネジ4.37	SCREW, SM4.37X9	
122-1	117516001	2	ボルト4.37	BOLT, M4.37	

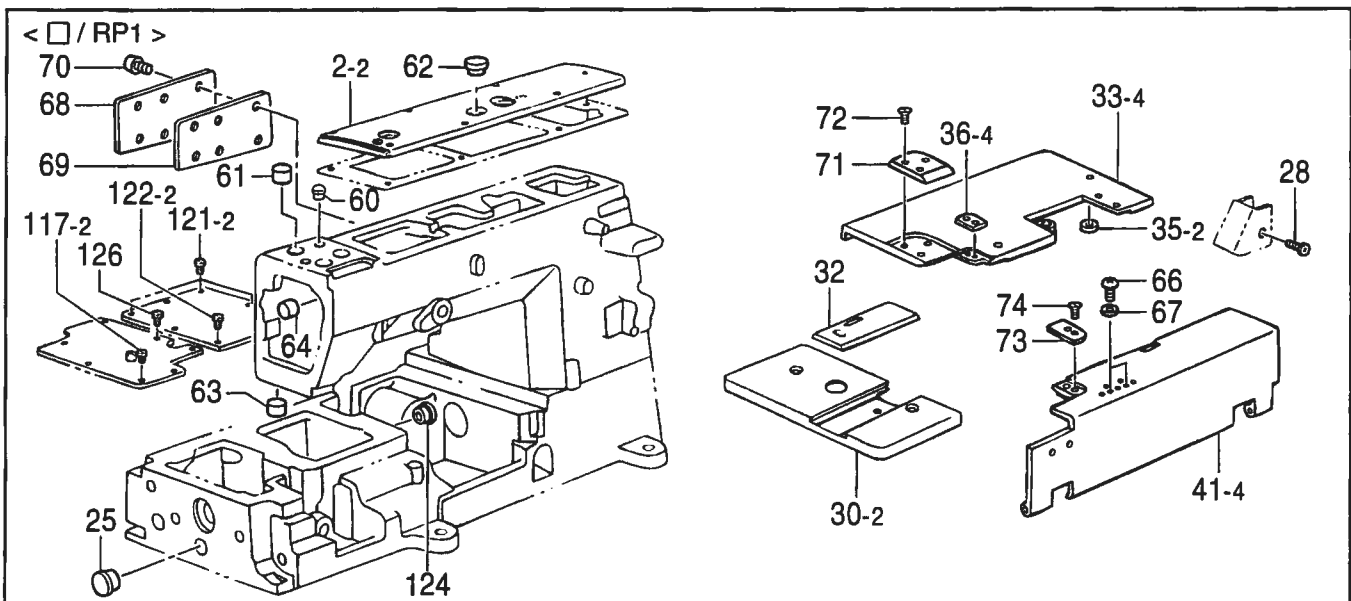
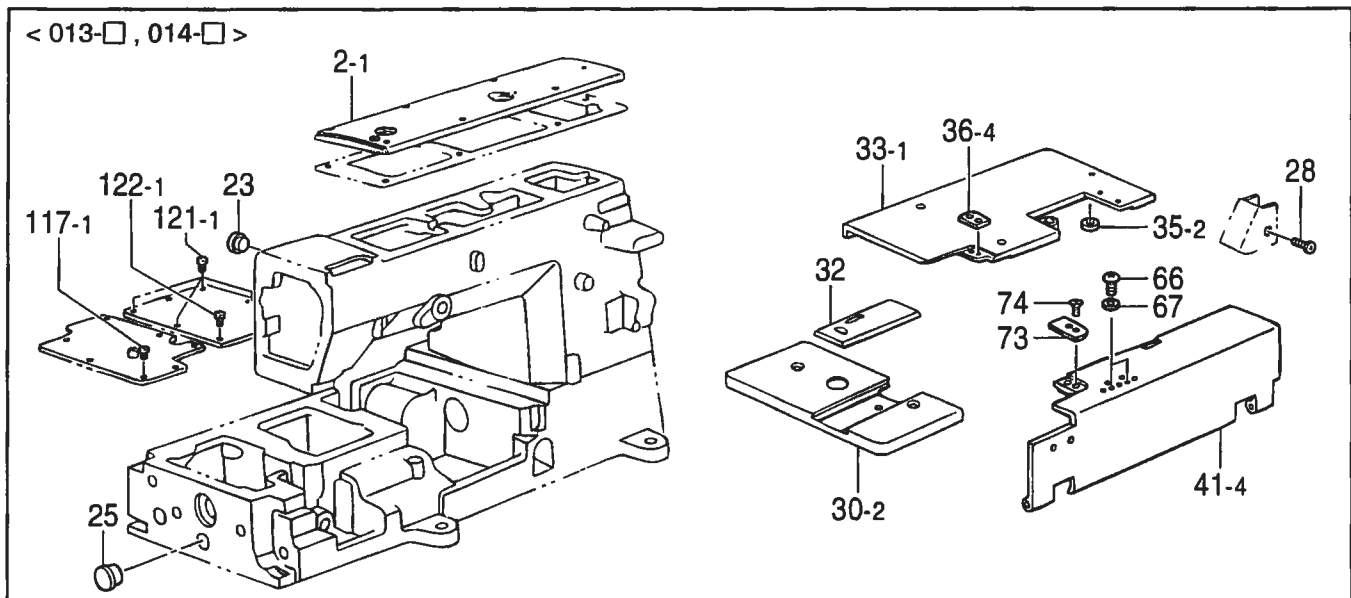
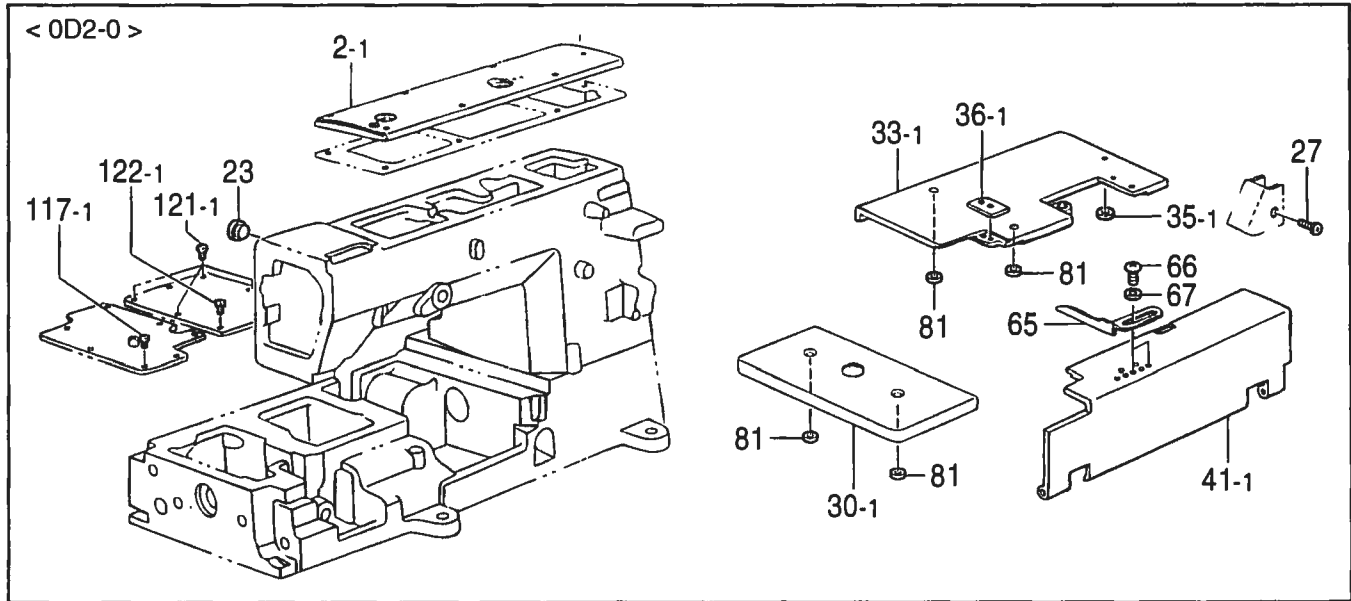

A. 主体関係 / Machine body / Maschinengehäuse / Corps de la machine / Cuerpo de la máquina

REF.NO.	CODE	Q'TY	ヒンメイ	NAME OF PARTS	RM
			<0D2-0>	<0D2-0>	
2-1	S08627001	1	ウワフタ	TOP COVER	
23	108520009	1	コムセン19.8	RUBBER CAP, 19.8	
27	062680812	1	ナベコ437-40X8	SCREW, PAN SM4.37-40X8	
30-1	S08634151	1	クロスプレートL	CLOTH PLATE (L)	
33-1	S08637001	1	クロスプレートR	CLOTH PLATE (R)	
35-1	S08639000	1	クロスプレートハツキン	CLOTH PLATE PACKING	
36-1	S08640001	1	クロスプレートホジヨイタ	SUB-CLOTH PLATE	
41-1	S08647101	1	マエカバー	FRONT COVER	
65	S40535001	1	ヌノガイド	CLOTH GUIDE	
66	062710812	2	ナベコ476-32X8	SCREW, PAN SM4.76-32X8	
67	146354001	2	ザガネ	WASHER, PLAIN 5	
81	S34200000	4	ソレノイドクツシヨウ	SOLENOID CUSHION	
117-1	107407003	6	シメネジ4.37	SCREW, SM4.37X9	
121-1	107407003	4	シメネジ4.37	SCREW, SM4.37X9	
122-1	117516001	2	ボルト4.37	BOLT, M4.37	
			<013-□, 014-□>	<013-□, 014-□>	
2-1	S08627001	1	ウワフタ	TOP COVER	
23	108520009	1	ゴムセン19.8	RUBBER CAP, 19.8	
25	158437009	1	ゴムセン10	RUBBER CAP, 10	
28	062681012	1	ナベコ437-40X10	SCREW, PAN SM4.37-40X10	
30-2	S40960051	1	クロスプレートL	CLOTH PLATE (L)	
32	S40961001	1	スベリイタ	SLIDE PLATE	
33-1	S08637001	1	クロスプレートR	CLOTH PLATE (R)	
35-2	025080132	1	ヒラザガネシヨウ8	WASHER, PLAIN S 8	
36-4	S44876001	1	クロスプレートホジヨイタ	CLOTH PLATE SUPPORT PLATE	
41-4	S44878101	1	マエカバー	FRONT COVER	
66	062710812	2	ナベコ476-32X8	SCREW, PAN SM4.76-32X8	
67	146354001	2	ザガネ	WASHER, PLAIN 5	
73	S44879001	1	マエカバーホジヨイタ	SUB FRONT COVER	
74	108960002	2	サラネジ3.57	SCREW, FLAT SM3.57	
117-1	107407003	6	シメネジ4.37	SCREW, SM4.37X9	
121-1	107407003	4	シメネジ4.37	SCREW, SM4.37X9	
122-1	117516001	2	ボルト4.37	BOLT, M4.37	
			<□/RP1>	<□/RP1>	
2-2	S12703001	1	ウワフタ	TOP COVER	
25	158437009	1	ゴムセン10	RUBBER CAP, 10	
28	062681012	1	ナベコ437-40X10	SCREW, PAN SM4.37-40X10	
30-2	S40960051	1	クロスプレートL	CLOTH PLATE (L)	
32	S40961001	1	スベリイタ	SLIDE PLATE	
33-4	S44875001	1	クロスプレートR	CLOTH PLATE (R)	
35-2	025080132	1	ヒラザガネシヨウ8	WASHER, PLAIN S 8	
36-4	S44876001	1	クロスプレートホジヨイタ	CLOTH PLATE SUPPORT PLATE	
41-4	S44878101	1	マエカバー	FRONT COVER	
60	104450109	2	ゴムセン8	RUBBER CAP, 8	
61	154841009	1	ゴムセン16.8	RUBBER CAP, 16.8	
62	159150009	1	ゴムセン20.5	RUBBER CAP, 20.5	
63	154841009	1	ゴムセン16.8	RUBBER CAP, 16.8	
64	156887001	1	ゴムセン17.5	RUBBER CAP, 17.5	
66	062710812	2	ナベコ476-32X8	SCREW, PAN SM4.76-32X8	
67	146354001	2	ザガネ	WASHER, PLAIN 5	
68	S28007001	1	ガワイタ	REAR COVER	
69	S28008000	1	ガワイタハツキン	REAR COVER PACKING	
70	062680812	6	ナベコ437-40X8	SCREW, PAN SM4.37-40X8	
71	S44877101	1	スベリイタ	SLIDE PLATE	
72	108960002	3	サラネジ3.57	SCREW, FLAT SM3.57	
73	S44879001	1	マエカバーホジヨイタ	SUB FRONT COVER	
74	108960002	2	サラネジ3.57	SCREW, FLAT SM3.57	
117-2	107407003	5	シメネジ4.37	SCREW, SM4.37X9	
121-2	107407003	3	シメネジ4.37	SCREW, SM4.37X9	
122-2	117516001	3	ボルト4.37	BOLT, M4.37	
124	S08673000	1	ゴムセン14	RUBBER CAP, 14	
126	117516001	1	ボルト4.37	BOLT, M4.37	

118-261-052

< 015-□ >

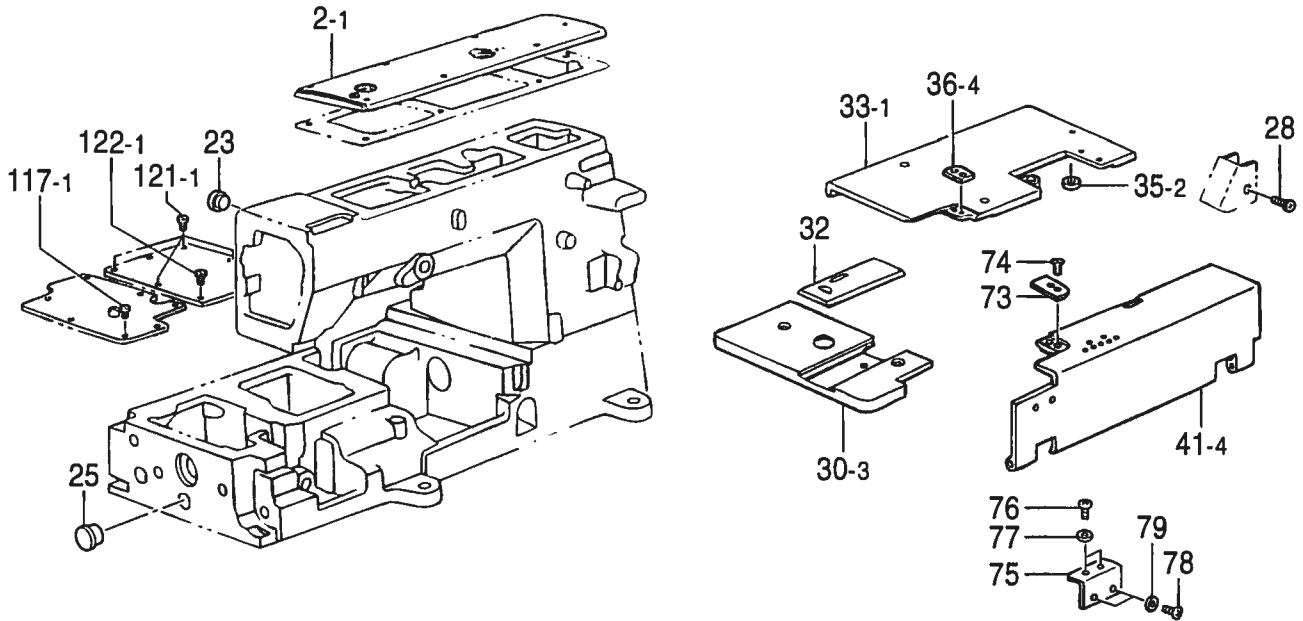

< オプションパーツ (中厚・タコ巻縫用・9.5ゲージ) >

< OPTION PARTS (FOR SEWING LAP SEAMS MEDIUM MATERIALS 9.5 GAUGE) >

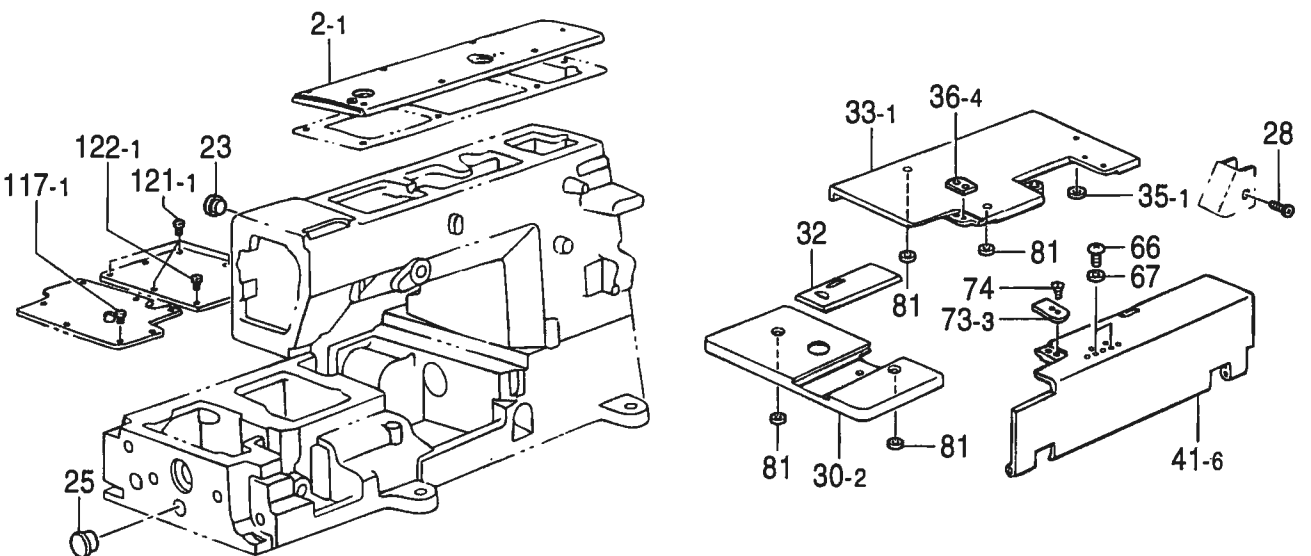

A. 主体関係 / Machine body / Maschinengehäuse / Corps de la machine / Cuerpo de la máquina

REF.NO.	CODE	Q'TY	ヒンメイ	NAME OF PARTS	RM
			<015-□>	<015-□>	
2-1	S08627001	1	ウワフタ	TOP COVER	
23	108520009	1	ゴムセン19.8	RUBBER CAP, 19.8	
25	158437009	1	ゴムセン10	RUBBER CAP, 10	
28	062681012	1	ナベコ437-40X10	SCREW, PAN SM4.37-40X10	
30-3	S48628001	1	クロスプレートL	CLOTH PLATE (L)	
32	S40961001	1	スベリイタ	SLIDE PLATE	
33-1	S08637001	1	クロスプレートR	CLOTH PLATE (R)	
35-2	025080132	1	ヒラザガネシヨウ8	WASHER, PLAIN S 8	
36-4	S44876001	1	クロスプレートホジヨイタ	CLOTH PLATE SUPPORT PLATE	
41-4	S44878101	1	マエカバー	FRONT COVER	
73	S44879001	1	マエカバーホシヨイタ	SUB FRONT COVER	
74	108960002	2	サラネジ3.57	SCREW, FLAT SM3.57	
75	S48629000	1	Gラツハトリツケイタ	G LAPPER SET PLATE	
76	062680812	2	ナベコ437-40X8	SCREW, PAN SM4.37-40X8	
77	146354001	2	ザガネ	WASHER, PLAIN 5	
78	062711012	2	ナベコ476-32X10	SCREW, PAN SM4.76-32X10	
79	146354001	2	ザガネ	WASHER, PLAIN 5	
117-1	107407003	6	シメネジ4.37	SCREW, SM4.37X9	
121-1	107407003	4	シメネジ4.37	SCREW, SM4.37X9	
122-1	117516001	2	ボルト4.37	BOLT, M4.37	
			<オプションパーツ (中厚タコ巻用9.5ゲージ)>	<OPTION PARTS (FOR SEWING LAP SEAMS MEDIUM MATERIALS 9.5GAUGE)>	
2-1	S08627001	1	ウワフタ	TOP COVER	
23	108520009	1	ゴムセン19.8	RUBBER CAP, 19.8	
25	158437009	1	ゴムセン10	RUBBER CAP, 10	
28	062681012	1	ナベコ437-40X10	SCREW, PAN SM4.37-40X10	
30-2	S40960051	1	クロスプレートL	CLOTH PLATE (L)	
32	S40961001	1	スベリイタ	SLIDE PLATE	
33-1	S08637001	1	クロスプレートR	CLOTH PLATE (R)	
35-1	S08639000	1	クロスプレートパツキン	CLOTH PLATE PACKING	
36-4	S44876001	1	クロスプレートホジヨイタ	CLOTH PLATE SUPPORT PLATE	
41-6	S47181001	1	マエカバー	FRONT COVER	
66	062710812	2	ナベコ476-32X8	SCREW, PAN SM4.76-32X8	
67	146354001	2	ザガネ	WASHER, PLAIN 5	
73-3	S47182001	1	マエカバーホジヨイタ	SUB FRONT COVER	
74	108960002	2	サラネジ3.57	SCREW, FLAT SM3.57	
81	S34200000	4	ソレノイドクツシヨウ	SOLENOID CUSHION	
117-1	107407003	6	シメネジ4.37	SCREW, SM4.37X9	
121-1	107407003	4	シメネジ4.37	SCREW, SM4.37X9	
122-1	117516001	2	ボルト4.37	BOLT, M4.37	

B. 上軸・針棒関係 / Upper shaft and needle bar mechanism / Obere Welle und Nadelstangenvorrichtung / Mécanisme de arbre supérieur et barra à aiguille / Mecanismo del eje superior y la barra de aguja

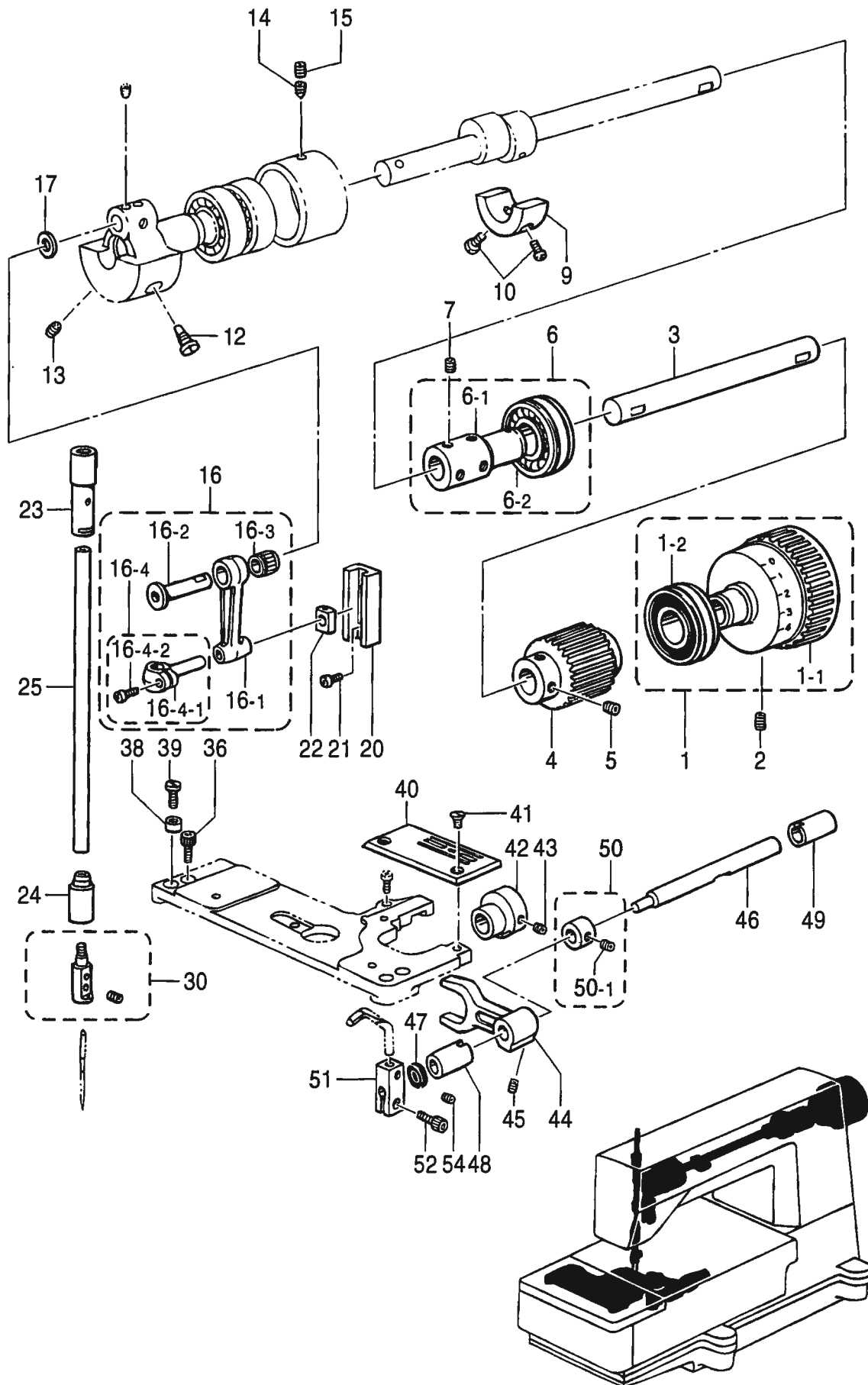

B. 上軸・針棒関係 / Upper shaft and needle bar mechanism / Obere Welle und Nadelstangenrichtung / Mécanisme de arbre supérieur et barra à aiguille / Mecanismo del eje superior y la barra de agua

REF.NO.	CODE	Q'TY	ヒンメイ	NAME OF PARTS	RM
1	S28957001	1	プーリクミ	PULLEY ASSY	
1-1	S28958001	1	プーリ	PULLEY	
1-2	S14621001	1	タマジクウケ6204LLB	BALL BEARING, 6204LLB	
2	014770622	2	アナトメネジ6.35クボミ	SET SCREW, SOCKET (CP) SM6.35	
3	S08682001	1	ウワシクR	UPPER SHAFT, R	
4	S08683000	1	タイミングプーリU	TIMING PULLEY, U	
5	014770622	4	アナトメネジ6.35クボミ	SET SCREW, SOCKET (CP) SM6.35	
6	S08684101	1	ツギテLクミ	JOINT ASSY, L	
6-1	S08685001	1	ツギテL	JOINT, L	
6-2	S08686101	1	タマジクウケ6204LU	BALL BEARING, 6204LU	
7	014770622	4	アナトメネジ6.35クボミ	SET SCREW, SOCKET (CP) SM6.35	
9	S08688051	1	ウエイト	WEIGHT	
10	062711012	2	ナベコ476-32X10	SCREW, PAN SM4.76-32X10	
12	104464001	1	シメネジ7.14	SCREW, SM7.14	
13	014770622	1	アナトメネジ6.35クボミ	SET SCREW, SOCKET (CP) SM6.35	
14	118853001	1	アナトメネジ5.95	SET SCREW, SOCKET SM5.95	
15	014760622	1	アナトメネジ5.95	SET SCREW, SOCKET SM5.95	
16	S08692101	1	ハリボウレンカンクミ	THREAD TAKE-UP LEVER SET	
16-1	S08693001	1	ハリボウレンカン	NEEDLE BAR CONNECTING ROD	
16-2	S08694001	1	ハリボウレンカンジク	THREAD TAKE-UP LEVER SHAFT	
16-3	S09120001	1	ニードルジクウケ	NEEDLE ROLLER BEARING	
16-4	S30086001	1	ハリボウダキクミ	NEEDLE BAR CLAMP ASSY	
16-4-1	S08695001	1	ハリボウダキ	NEEDLE BAR CLAMP	
16-4-2	100064005	1	シメネジ3.57	SCREW, SM3.57	
17	107153001	1	ザガネ	WASHER	
20	145688000	1	ハリボウアンナイ	NEEDLE BAR GUIDE	
21	062670612	2	ナベコ357-40X6	SCREW, PAN SM3.57-40X6	
22	102630001	1	ハリボウアンナイカクコマ	SLIDE BLOCK, N-BAR GUIDE	
23	S08696000	1	ハリボウメタルU	NEEDLE BAR BUSH, U	
24	S08697000	1	ハリボウメタルD	NEEDLE BAR BUSH, D	
25	S08698001	1	ハリボウ	NEEDLE BAR	
30	※	1	ハリドメ1クミ	NEEDLE CLAMP ASSY	
36	018681022	2	アナボルト4.37X10	BOLT, SOCKET SM4.37X10	
38	S09124001	2	ハリイタササエイタカラー	COLLER	
39	S13385001	2	シメネジ3.57X10	SCREW, SM3.57X10	
40	※	1	ハリイタ	NEEDLE PLATE	
41	S09121001	2	マルサラネジ3.57X6	SCREW, FLAT M3.57X6	
42	S08750001	1	ハリウケBヘンシンリン	NEEDLE GUARD REAR ECCENTRIC WHEEL	
43	014680622	2	アナトメネジ4.37クボミ	SET SCREW, SOCKET (CP) SM4.37	
44	S08751001	1	ハリウケBレバー	NEEDLE GUARD REAR LEVER	
45	014680622	2	アナトメネジ4.37クボミ	SET SCREW, SOCKET (CP) SM4.37	
46	S08752001	1	ハリウケBジク	NEEDLE GUARD REAR SHAFT	
47	155539000	1	ダストシール	DUST SEAL	
48	S08753000	1	ハリウケBジクメタルL	KNIFE DRIVING SHAFT BUSH (L)	
49	S08754000	1	ハリウケBジクメタルR	KNIFE DRIVING SHAFT BUSH (R)	
50	S03704002	1	セツトカラークミ	SET SCREW COLLAR ASSY	
50-1	014770622	2	アナトメネジ6.35クボミ	SET SCREW, SOCKET (CP) SM6.35	
51	S08755101	1	ハリウケBトリツケダイ	NEEDLE GUARD BACK SET BRACKET	
52	018681022	1	アナボルト4.37X10	BOLT, SOCKET SM4.37X10	
54	014680422	1	アナトメネジ4.37クボミ	SET SCREW, SOCKET (CP) SM4.37	



B. 上軸・針棒関係 / Upper shaft and needle bar mechanism / Obere Welle und Nadelstangenvorrichtung / Mécanisme de arbre supérieur et barra à aiguille / Mecanismo del eje superior y la barra de aguaja

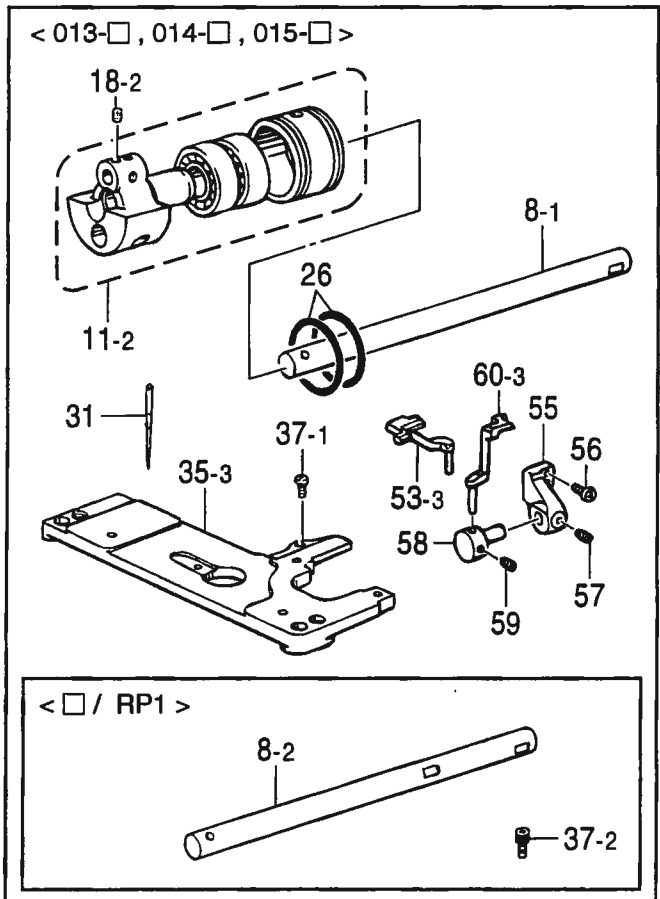
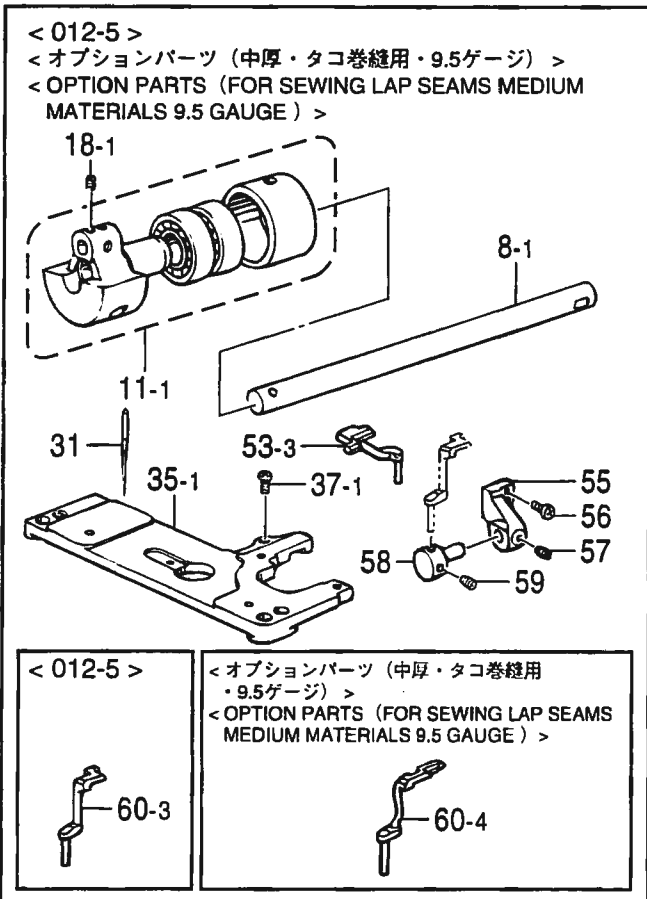
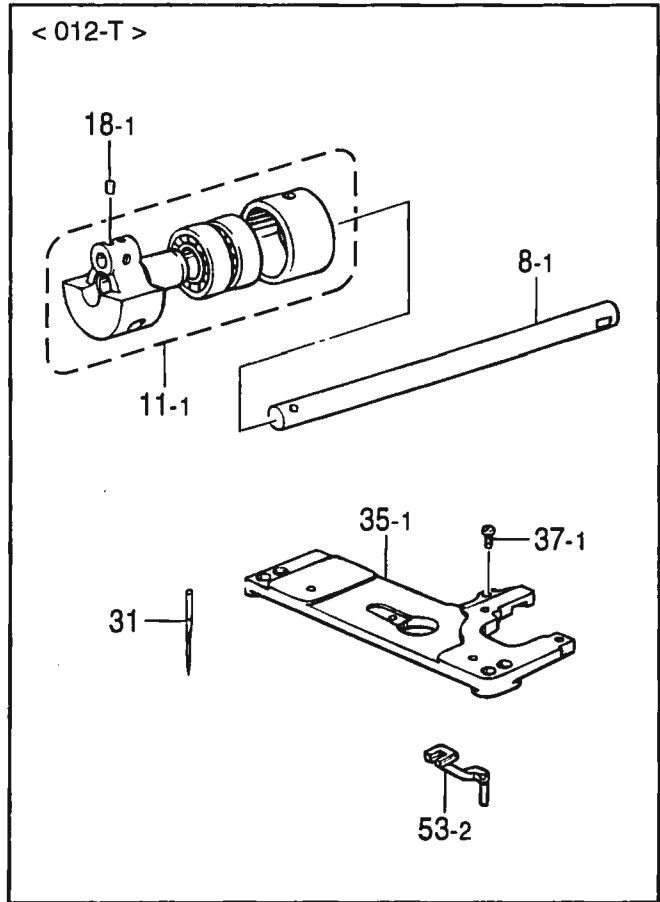
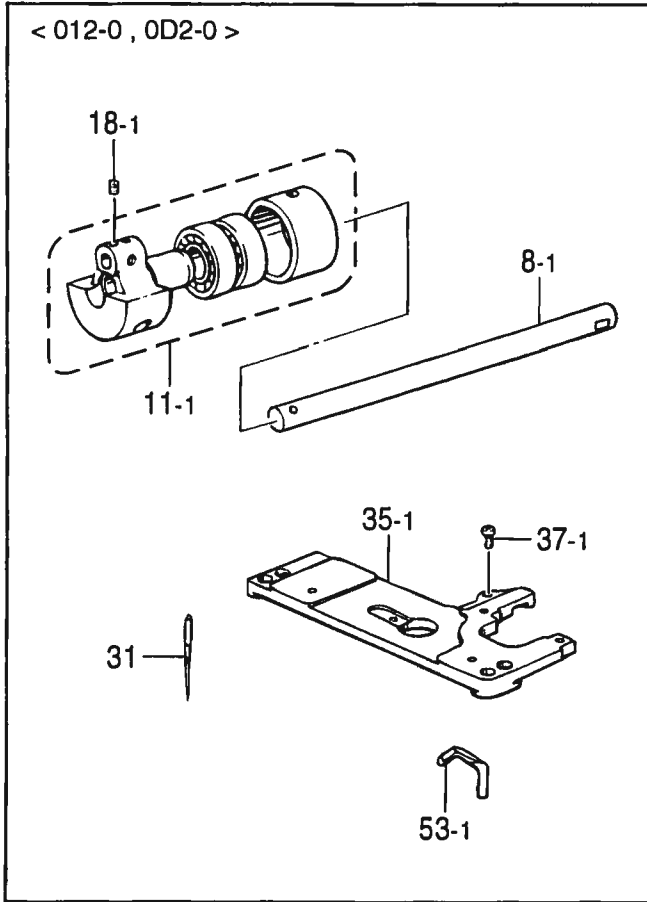

B. 上軸・針棒関係 / Upper shaft and needle bar mechanism / Obere Welle und Nadelstangenvorrichtung / Mécanisme de arbre supérieur et barra à aiguille / Mecanismo del eje superior y la barra de aguaja

REF.NO.	CODE	Q'TY	ヒンメイ	NAME OF PARTS	RM
8-1	S08687001	1	<012-0,0D2-0> ウワジクL	<012-0,0D2-0> ARM SHAFT (L)	
11-1	S08689001	1	テンピンクランククミ	NEEDLE BAR CRANK ASSY	
18-1	014760622	3	アナトメネジ5.95	SET SCREW, SOCKET SM5.95	
31	S08715016	1	ミシンハリUYX128GAS	NEEDLE, UYX128GAS (#16)	
35-1	S08716301	1	ハリイタササエイタ	SUPPORTER PLATE, NEEDLE PLATE	
37-1	062680812	1	ナベコ437-40X8	SCREW, PAN SM4.37-40X8	
53-1	S08756001	1	ハリウケB	NEEDLE GUARD REAR	
8-1	S08687001	1	<012-T> ウワジクL	<012-T> ARM SHAFT (L)	
11-1	S08689001	1	テンピンクランククミ	NEEDLE BAR CRANK ASSY	
18-1	014760622	3	アナトメネジ5.95	SET SCREW, SOCKET SM5.95	
31	S08715016	2	ミシンハリUYX128GAS	NEEDLE, UYX128GAS (#16)	
35-1	S08716301	1	ハリイタササエイタ	SUPPORTER PLATE, NEEDLE PLATE	
37-1	062680812	1	ナベコ437-40X8	SCREW, PAN SM4.37-40X8	
53-2	S40967001	1	ウシロハリウケT	REAR NEEDLE GUARD (T)	
8-1	S08687001	1	<013-□> ウワジクL	<013-□> ARM SHAFT (L)	
11-2	S12725101	1	ハリボウクランククミ	NEEDLE BAR CRANK ASSY	
18-2	152718001	3	アナトメネジ5.95	SET SCREW, SOCKET M5.95	
26	081046870	2	OリングS46	O RING, S46	
31	S08715021	2	ミシンハリUYX128GAS	NEEDLE, UYT128GAS	
35-3	S44882001	1	ハリイタササエイタ	NEEDLE PLATE SUPPORT	
37-1	062680812	1	ナベコ437-40X8	SCREW, PAN SM4.37-40X8	
53-3	S40985201	1	ウシロハリウケH	REAR NEEDLE GUARD (H)	
55	S40965001	1	マエハリウケドダイ	FRONT NEEDLE GUARD BRACKET	
56	062671012	2	ナベコ357-40X10	SCREW, PAN SM3.57-40X10	
57	014680422	1	アナトメネジ4.37クボミ	SET SCREW, SOCKET (CP) SM4.37	
58	S40966001	1	マエハリウケホルダー	FRONT NEEDLE GUARD HOLDER	
59	014680422	1	アナトメネジ4.37クボミ	SET SCREW, SOCKET (CP) SM4.37	
60-3	S40986101	1	マエハリウケH	FRONT NEEDLE GUARD (H)	
8-1	S08687001	1	<014-□> ウワジクL	<014-□> ARM SHAFT (L)	
11-2	S12725101	1	ハリボウクランククミ	NEEDLE BAR CRANK ASSY	
18-2	152718001	3	アナトメネジ5.95	SET SCREW, SOCKET M5.95	
26	081046870	2	OリングS46	O RING, S46	
31	S08715022	2	ミシンハリUYX128GAS	NEEDLE, UYT128GAS	
35-3	S44882001	1	ハリイタササエイタ	NEEDLE PLATE SUPPORT	
37-1	062680812	1	ナベコ437-40X8	SCREW, PAN SM4.37-40X8	
53-3	S40985201	1	ウシロハリウケH	REAR NEEDLE GUARD (H)	
55	S40965001	1	マエハリウケドダイ	FRONT NEEDLE GUARD BRACKET	
56	062671012	2	ナベコ357-40X10	SCREW, PAN SM3.57-40X10	
57	014680422	1	アナトメネジ4.37クボミ	SET SCREW, SOCKET (CP) SM4.37	
58	S40966001	1	マエハリウケホルダー	FRONT NEEDLE GUARD HOLDER	
59	014680422	1	アナトメネジ4.37クボミ	SET SCREW, SOCKET (CP) SM4.37	
60-3	S40986101	1	マエハリウケH	FRONT NEEDLE GUARD (H)	
8-2	S12724001	1	<013-□/RP1> ウワジクL	<013-□/RP1> UPPER SHAFT, L	
11-2	S12725101	1	ハリボウクランククミ	NEEDLE BAR CRANK ASSY	
18-2	152718001	3	アナトメネジ5.95	SET SCREW, SOCKET M5.95	
26	081046870	2	OリングS46	O RING, S46	
31	S08715021	2	ミシンハリUYX128GAS	NEEDLE, UYT128GAS	
35-3	S44882001	1	ハリイタササエイタ	NEEDLE PLATE SUPPORT	
37-2	018681022	1	アナボルト4.37X10	BOLT, SOCKET SM4.37X10	
53-3	S40985201	1	ウシロハリウケH	REAR NEEDLE GUARD (H)	
55	S40965001	1	マエハリウケドダイ	FRONT NEEDLE GUARD BRACKET	
56	062671012	2	ナベコ357-40X10	SCREW, PAN SM3.57-40X10	
57	014680422	1	アナトメネジ4.37クボミ	SET SCREW, SOCKET (CP) SM4.37	
58	S40966001	1	マエハリウケホルダー	FRONT NEEDLE GUARD HOLDER	

B. 上軸・針棒関係 / Upper shaft and needle bar mechanism / Obere Welle und Nadelstangenvorrichtung / Mécanisme de arbre supérieur et barra à aiguille / Mecanismo del eje superior y la barra de aguja

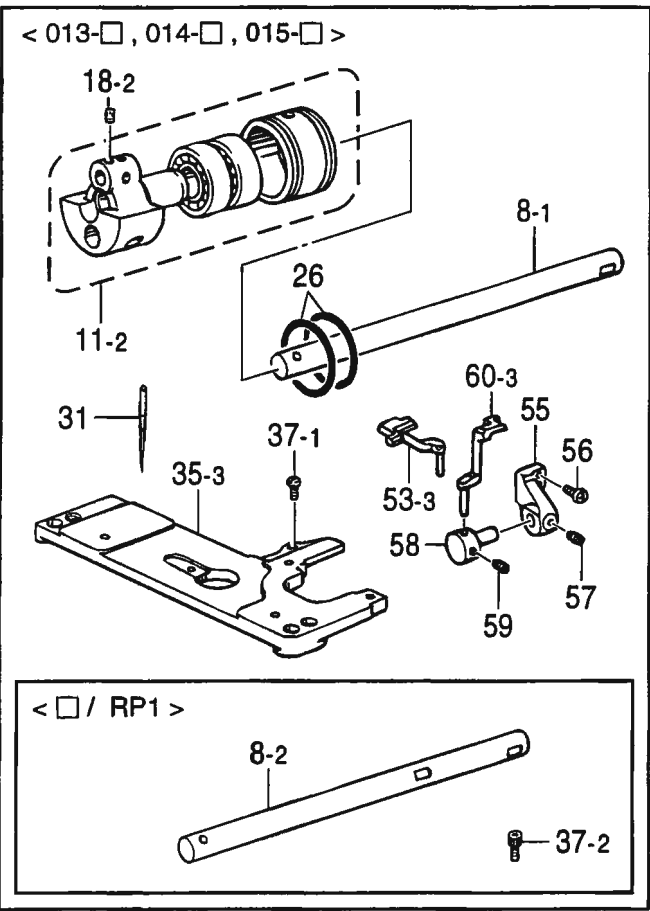
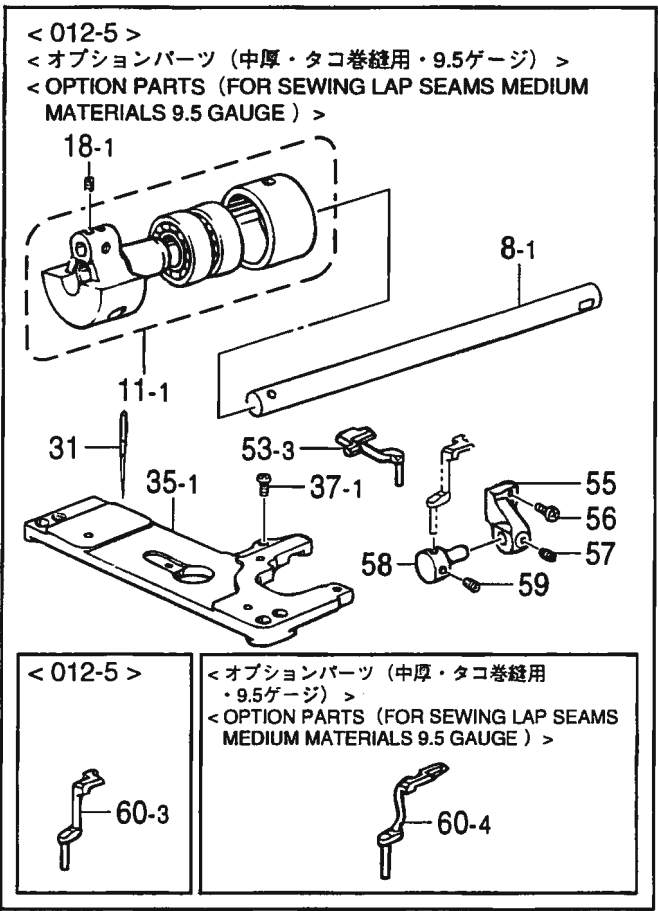
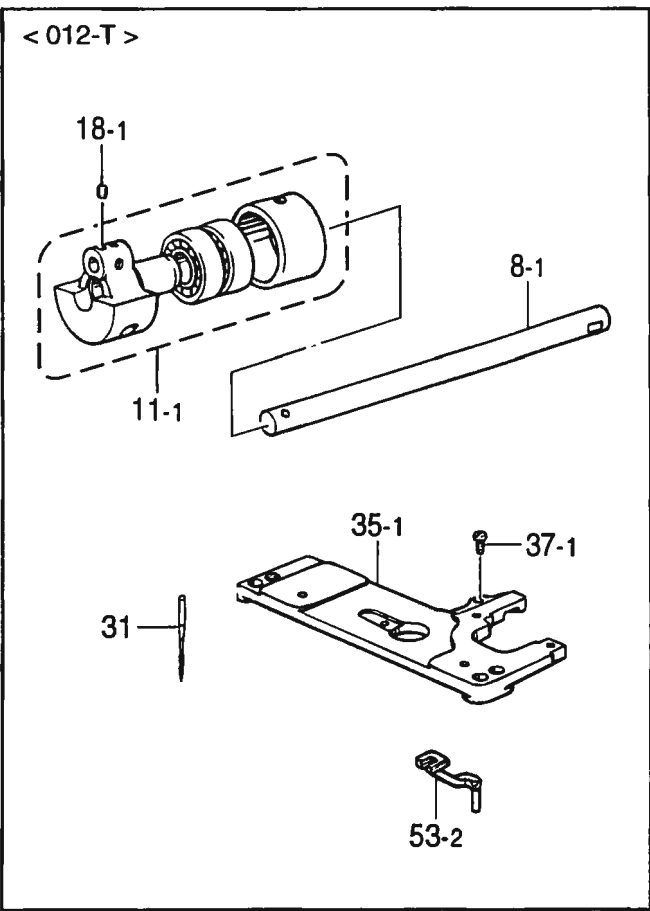
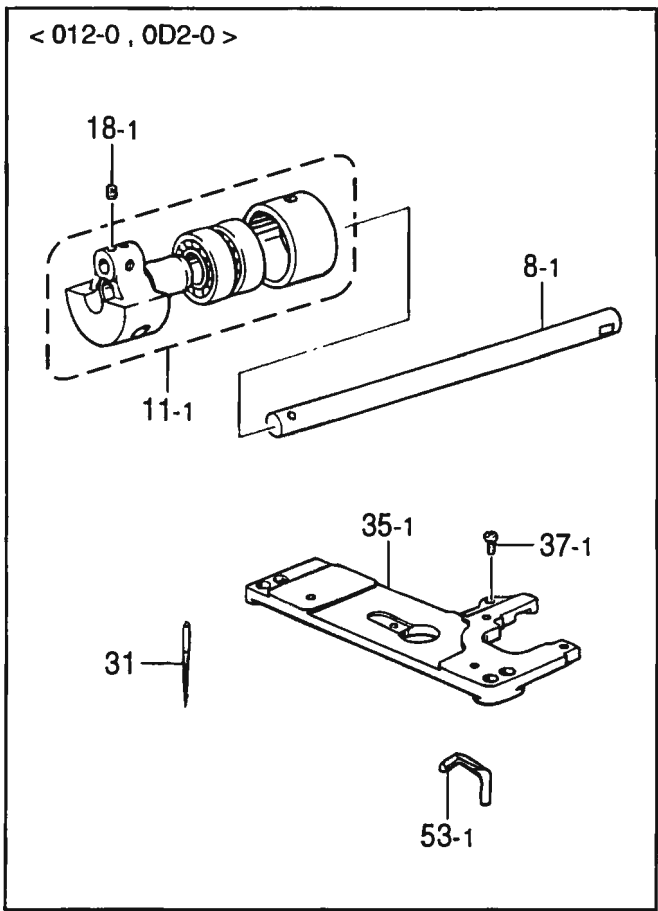

B. 上軸・針棒関係 / Upper shaft and needle bar mechanism / Obere Welle und Nadelstangenvorrichtung / Mécanisme de arbre supérieur et barra à aiguille / Mecanismo del eje superior y la barra de aguja

REF.NO.	CODE	Q'TY	ヒンメイ	NAME OF PARTS	RM
59	014680422	1	アナトメネジ4.37クボミ	SET SCREW, SOCKET (CP) SM4.37	
60-3	S40986101	1	マエハリウケH	FRONT NEEDLE GUARD (H)	
			<014-□/RP1>	<014-□/RP1>	
8-2	S12724001	1	ウワジクL	UPPER SHAFT, L	
11-2	S12725101	1	ハリボウ克蘭ククミ	NEEDLE BAR CRANK ASSY	
18-2	152718001	3	アナトメネジ5.95	SET SCREW, SOCKET M5.95	
26	081046870	2	OリングS46	O RING, S46	
31	S08715022	2	ミシンハリUYX128GAS	NEEDLE, UYT128GAS	
35-3	S44882001	1	ハリイタササエイタ	NEEDLE PLATE SUPPORT	
37-2	018681022	1	アナボルト4.37X10	BOLT, SOCKET SM4.37X10	
53-3	S40985201	1	ウシロハリウケH	REAR NEEDLE GUARD (H)	
55	S40965001	1	マエハリウケドダイ	FRONT NEEDLE GUARD BRACKET	
56	062671012	2	ナベコ357-40X10	SCREW, PAN SM3.57-40X10	
57	014680422	1	アナトメネジ4.37クボミ	SET SCREW, SOCKET (CP) SM4.37	
58	S40966001	1	マエハリウケホルダー	FRONT NEEDLE GUARD HOLDER	
59	014680422	1	アナトメネジ4.37クボミ	SET SCREW, SOCKET (CP) SM4.37	
60-3	S40986101	1	マエハリウケH	FRONT NEEDLE GUARD (H)	
			<012-5>	<012-5>	
			<オプションパーツ (中厚タコ巻縫用9.5ゲージ)>	<OPTION PARTS (FOR SEWING LAP SEAMS MEDIUM MATERIALS 9.5GAUGE)>	
8-1	S08687001	1	ウワジクL	ARM SHAFT (L)	
11-1	S08689001	1	テンピン克蘭ククミ	NEEDLE BAR CRANK ASSY	
18-1	014760622	3	アナトメネジ5.95	SET SCREW, SOCKET SM5.95	
31	S08715016	2	ミシンハリUYX128GAS	NEEDLE, UYX128GAS (#16)	
35-1	S08716301	1	ハリイタササエイタ	SUPPORTER PLATE, NEEDLE PLATE	
37-1	062680812	1	ナベコ437-40X8	SCREW, PAN SM4.37-40X8	
53-3	S40985201	1	ウシロハリウケH	REAR NEEDLE GUARD (H)	
55	S40965001	1	マエハリウケドダイ	FRONT NEEDLE GUARD BRACKET	
56	062671012	2	ナベコ357-40X10	SCREW, PAN SM3.57-40X10	
57	014680422	1	アナトメネジ4.37クボミ	SET SCREW, SOCKET (CP) SM4.37	
58	S40966001	1	マエハリウケホルダー	FRONT NEEDLE GUARD HOLDER	
59	014680422	1	アナトメネジ4.37クボミ	SET SCREW, SOCKET (CP) SM4.37	
			<012-5>	<012-5>	
60-3	S40986101	1	マエハリウケH	FRONT NEEDLE GUARD (H)	
			<オプションパーツ (中厚タコ巻縫用9.5ゲージ)>	<OPTION PARTS (FOR SEWING LAP SEAMS MEDIUM MATERIALS 9.5GAUGE)>	
60-4	S45089001	1	マエハリウケH3/8	FRONT NEEDLE GUARD (H)3/8	

C. 針冷却関係 / Needle cooler / Nedelkühlungsvorrichtung / Mécanisme du refroidisseur d'aiguille / Mecanismo del enfriador de aguja

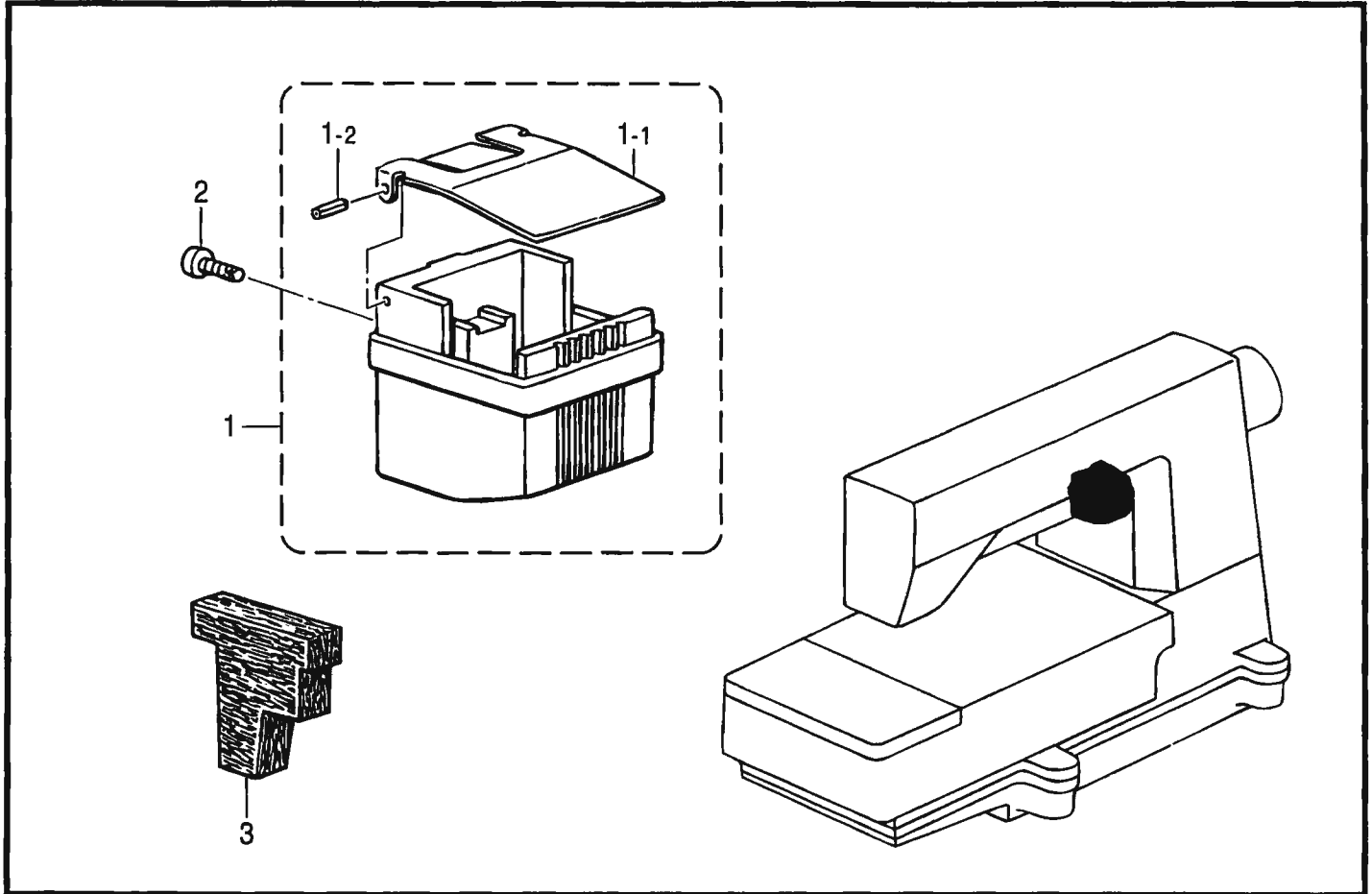

118-261-124

D. ラッパー関係 / Lapper mechanism / Falz-mechanismus / Mécanisme à rabat / Mecanismo de solapado

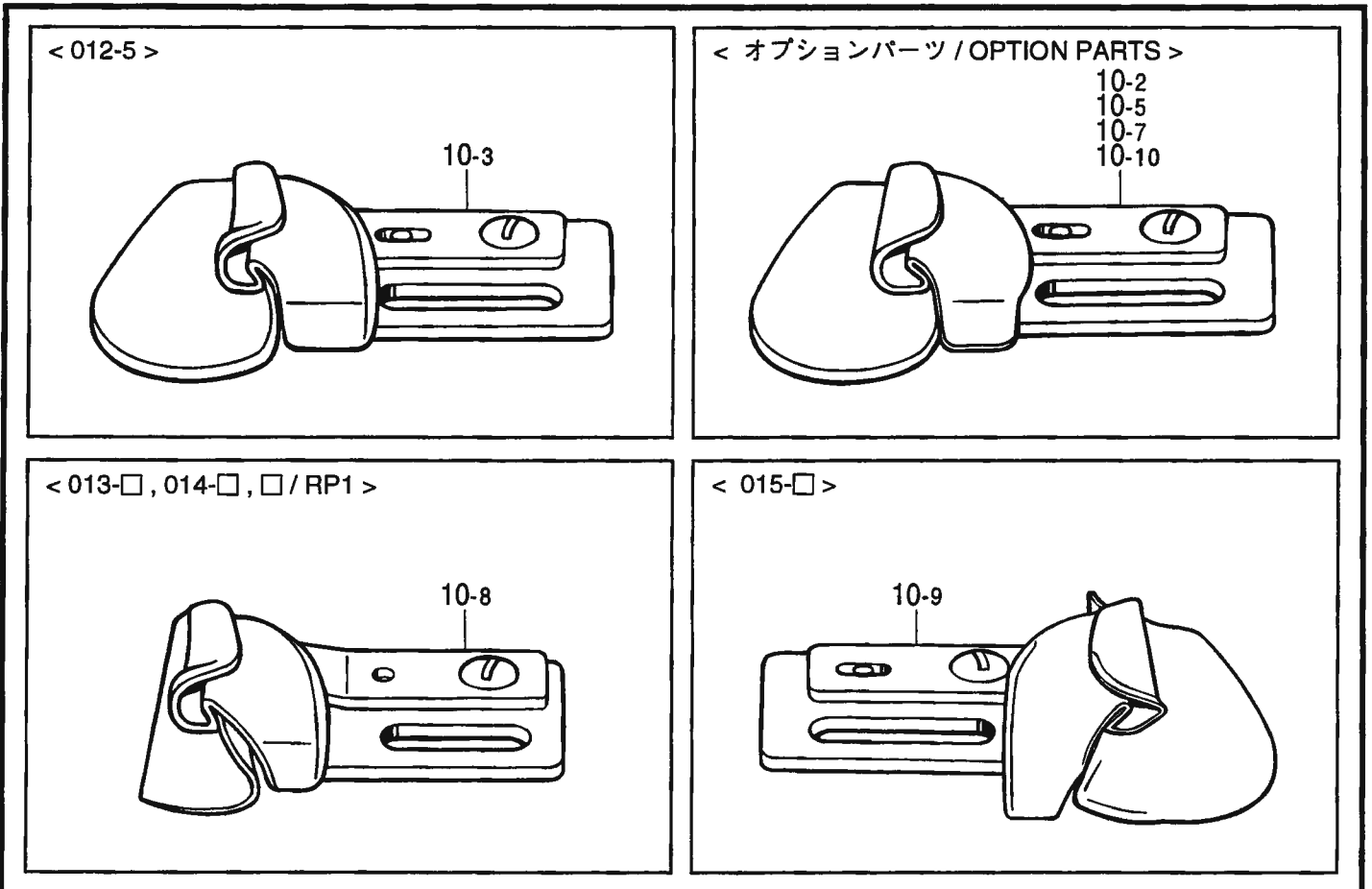

118-261-239

C. 針冷却関係 / Needle cooler / Nadelkühlungsvorrichtung / Mécanisme du refroidisseur  
d'aiguille / Mecanismo del enfriador de aguja

REF.NO.	CODE	Q'TY	ヒンメイ	NAME OF PARTS	RM
1	S08758109	1	ハリイトレイキヤクタンククミ	N/THREAD COOLER TANK ASSY	
1-1	S08760009	1	ハリイトレイキヤクタンクフタ	N/THREAD COOLER TANK COVER	
1-2	047200642	2	スプリングピンAW2	PIN, SPRING ROLL AW2	
2	087311215	2	カツフBタイト3X12	TAPTITE, CUP B M3X12	
3	S08761100	1	ハリイトレイキヤクフェルト	FELT	

118-261-124

D. ラッパ-関係 / Lapper mechanism / Falz-mechanismus / Mécanisme à rabat / Mecanismo de solapado

REF.NO.	CODE	Q'TY	ヒンメイ	NAME OF PARTS	RM
10-3	113880001	1	<012-5> ラツハークミ1/4	<012-5> LAPPER 1/4" ASSY	
10-8	S44912000	1	<013-□,014-□,□/RP1> ラツハー1/4XHクミ	<013-□,014-□,□/RP1> LAPPER 1/4"XH ASSY	
10-9	S48630001	1	<015-□> ラツハー1/4XHクミ	<015-□> LAPPER 1/4"XH ASSY	
10-2	115834001	1	<オプションパーツ> (中厚 4.8ゲージ用) ラツパー3/16クミ	<OPTION PARTS > (MEDIUM MATERIALS 4.8 GAUGE) LAPPER ASSY 3/16" ASSEMBLY	
10-5	151584001	1	(薄物 6.4ゲージ用) ラツパー1/4Mクミ	(THIN MATERIALS 6.4 GAUGE) LAPPER ASSY 1/4" M ASSEMBLY	
10-7	S37818001	1	(中厚 9.5ゲージ用) ラツパー3/8MHクミ	(MEDIUM MATERIALS 9.5 GAUGE) LAPPER ASSY 3/16" MH ASSEMBLY	
10-10	S49420001	1	(薄物 4.8ゲージ用) ラッパ-3/16Mクミ	(THIN MATERIALS 4.8 GAUGE) LAPPER 3/16" M ASSY	

118-261-239

E . 押工関係 / Presser foot mechanism / Stoffdrückerfuß / Mécanisme de pied presseur / Mecanismo de la prensa tela

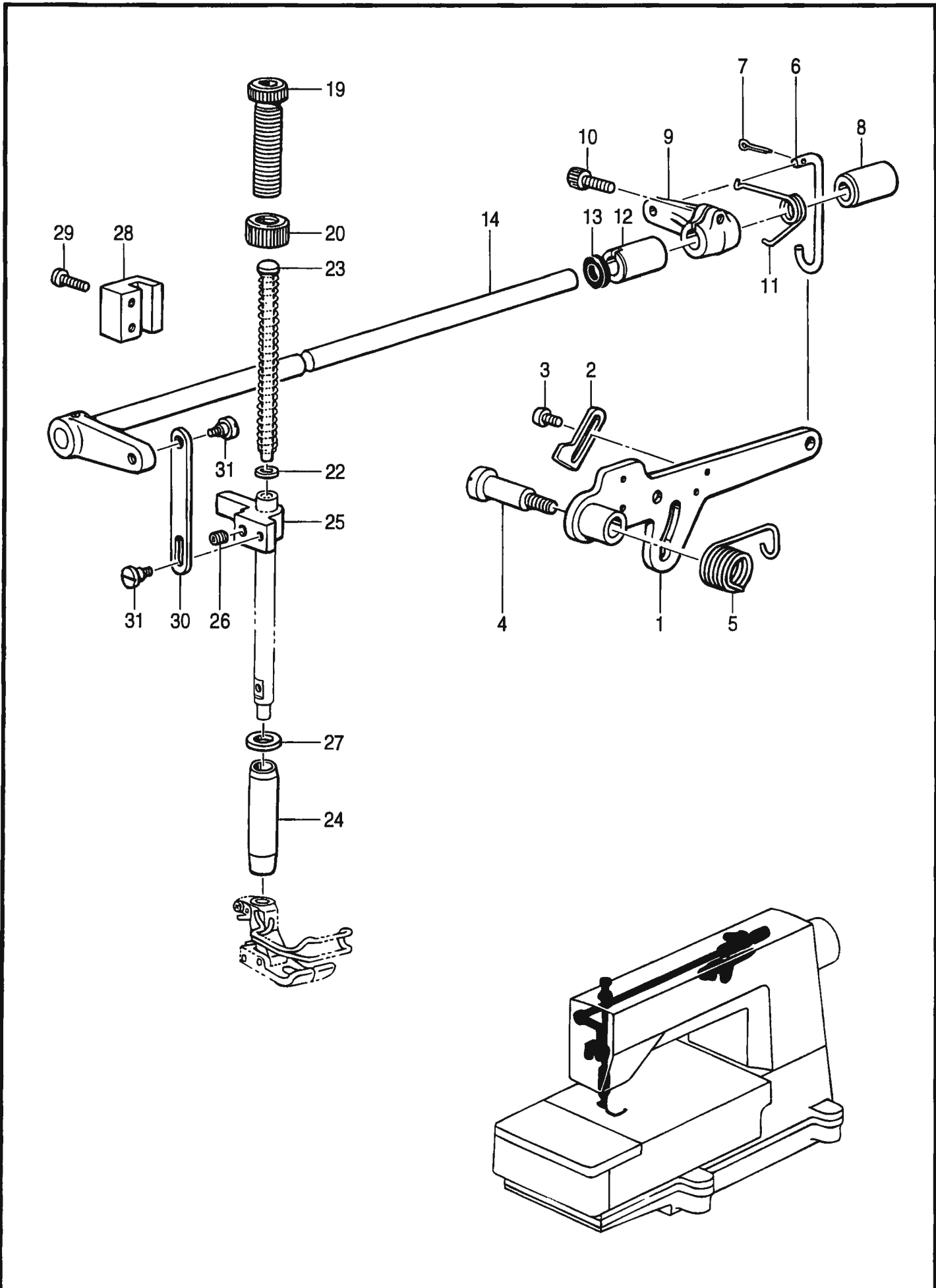

118-261-201

E. 押工関係 / Presser foot mechanism / Stoffdrückerfuß / Mécanisme de pied presseur /  
Mecanismo de la prensa tela

REF.NO.	CODE	Q'TY	ヒンメイ	NAME OF PARTS	RM
1	S08767001	1	オサエアゲレバーR	PRESSER BAR LIFTER LEVER (R)	
2	S08768001	1	オサエアゲストツハ	PRESSER BAR LIFTER LEVER STOPPER	
3	060680712	2	バインド437-40X7	SCREW, BIND SM4.37-40X7	
4	148372001	1	ダンネジ7.94	STUD SCREW, M7.94	
5	143325001	1	オサエアシアゲレバーバネ	SPRING	
6	S08769001	1	オサエアゲリンク	PRESSER BAR LIFTER LINK	
7	110793001	1	ワリヒン	PIN, COTTER	
8	155220000	1	ホジヨアツメタルR	AUTO PRESSER ARM BUSH (R)	
9	154956001	1	オサエアシアゲMレバー	PRESSER FOOT LIFTER INSIDE LEVER	
10	018771432	1	アナホルト635-40X14	BOLT, SOCKET SM6.35-40X14	
11	154957001	1	オサエアゲMレバーバネ	SPRING	
12	S08770000	1	ジクメタル	SHAFT BUSH	
13	155539000	1	ダストシール	DUST SEAL	
14	S08771001	1	オサエアゲレバーLクミ	PRESSER BAR LIFTER LEVER (L) ASSY	
19	S31012001	1	オサエ子ヨウセツネジ	ADJUSTING SCREW, PRESSER	
20	S31013001	1	子ヨウセツネジツマミナツト	ADJUSTING NUT, PRESSER	
22	140407001	1	ザガネ	WASHER	
23	141208001	1	オサエバネアンナイ	SPRING GUIDE	
24	145472001	1	オサエボウメタル	BUSH, PRESSER BAR	
25	S00879001	1	オサエボウダキ	GUIDE BRACKET, P-BAR	
26	014760622	1	アナトメネジ5.95	SET SCREW, SOCKET SM5.95	
27	154596000	1	イトキリカムレバークツシヨン	CUSHION	
28	S08775000	1	オサエボウアンナイ	PRESSER BAR GUIDE	
29	062681412	2	ナベコ437-40X14	SCREW, PAN SM4.37-40X14	
30	S08776001	1	オサエアゲイタ	PRESSER BAR LIFTER PLATE	
31	S08777001	2	ダンネジ4.37	SHOULDER SCREW, M4.37	



E . 押工関係 / Presser foot mechanism / Stoffdrückerfuß / Mécanisme de pied presseur / Mecanismo de la prensa tela

< 012-0 , 0D2-0 , 012-T >

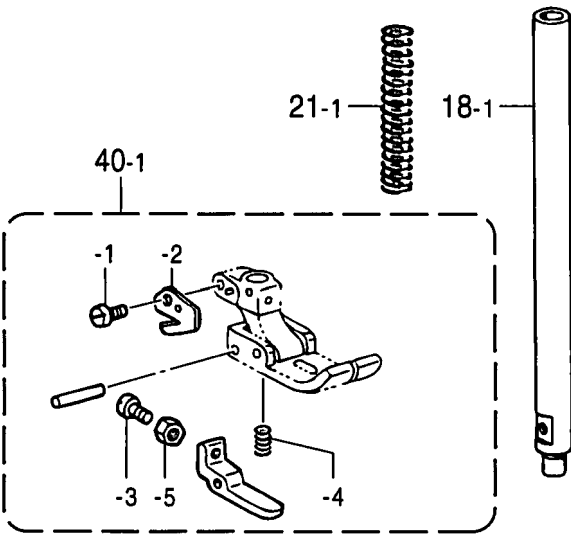

< 012-0 >

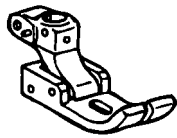

< 0D2-0 >

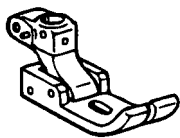

< 012-T >

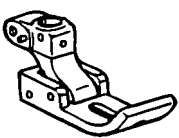

< 012-5 >

< オプションパーツ (中厚・タコ巻縫用・9.5ゲージ) >

< OPTION PARTS (FOR SEWING LAP SEAMS MEDIUM MATERIALS 9.5 GAUGE) >

< オプションパーツ (中厚・タコ巻縫用・4.8ゲージ) >

< OPTION PARTS (FOR SEWING LAP SEAMS MEDIUM MATERIALS 4.8 GAUGE) >

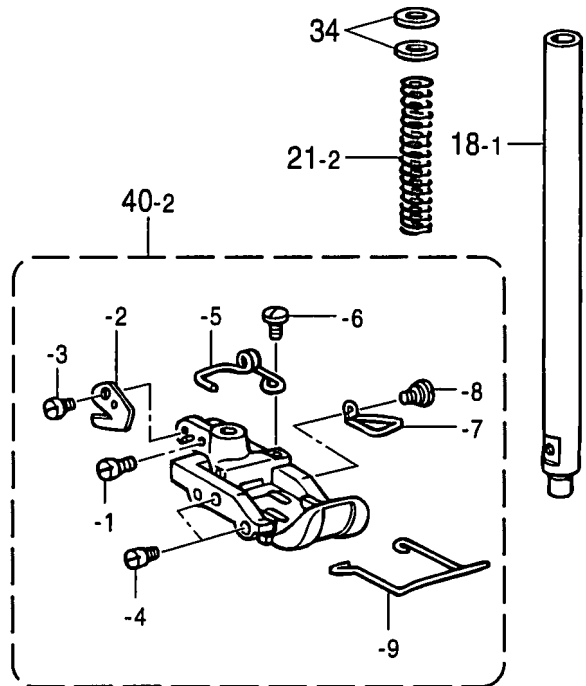

< オプションパーツ (フィーディングフット) >

< OPTION PARTS (FOR FEEDING PRESSER FOOT) >

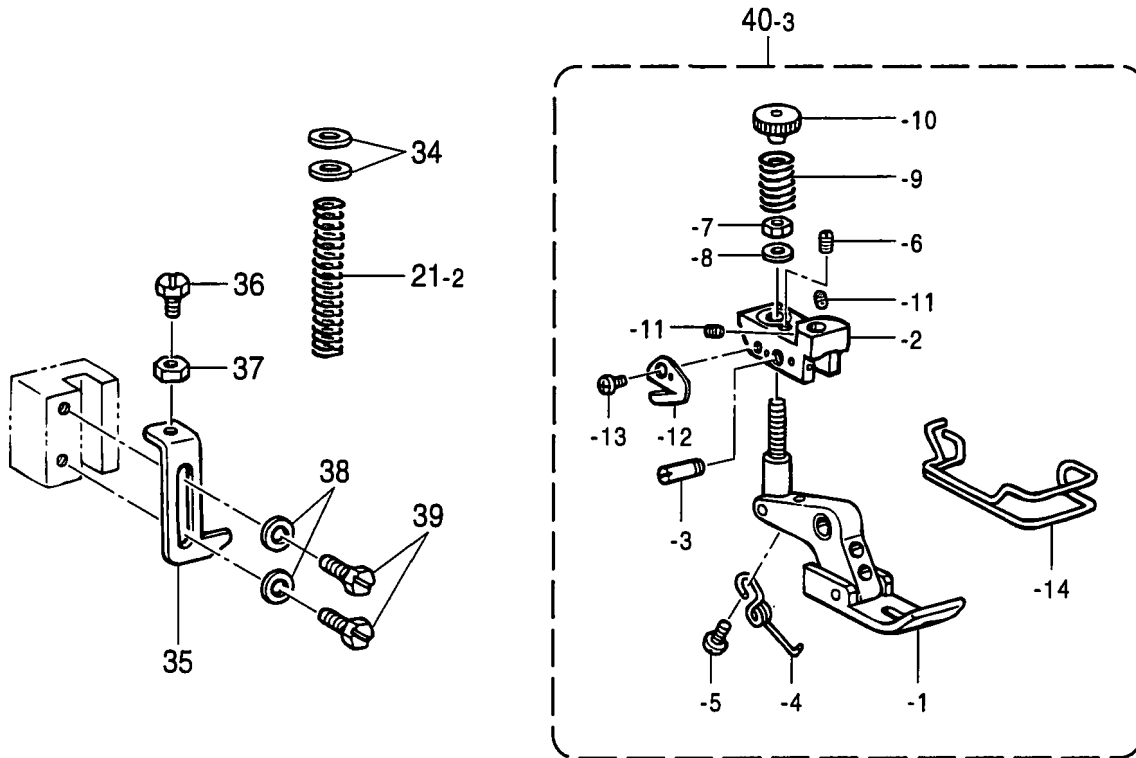

E. 押工関係 / Presser foot mechanism / Stoffdrückerfuß / Mécanisme de pied presseur / Mecanismo de la prensa tela

REF.NO.	CODE	Q'TY	ヒンメイ	NAME OF PARTS	RM
			<012-0,012-T,0D2-0>	<012-0,012-T,0D2-0>	
18-1	S08774001	1	オサエボウ	PRESSER BAR	
21-1	141728001	1	オサエバネ	PRESSER SPRING	
40-1	※	1	オサエクミ	PRESSER FOOT ASSY	
40-1-1	062671212	1	ナベコ357-40X12	SCREW, PAN SM3.57-40X12	
40-1-2	S20118151	1	カラヌイメス	TRIMMING KNIFE	
40-1-3	062630612	1	ナベコ238-56X6	SCREW, PAN SM2.38-56X6	
40-1-4	S40546001	1	カラカンオサエバネ	CHAIN GUIDE SPRING	
40-1-5	S47932001	1	ナツト238-56		
			<012-5>	<012-5>	
			<オプションパーツ (中厚タコ巻縫用9.5ゲージ)>	<OPTION PARTS(FOR SEWING LAP SEAMS MEDIUM MATERIALS 9.5 GAUGE)>	
			<オプションパーツ (中厚タコ巻縫用4.8ゲージ)>	<OPTION PARTS(FOR SEWING LAP SEAMS MEDIUM MATERIALS 4.8 GAUGE)>	
18-1	S08774001	1	オサエボウ	PRESSER BAR	
21-2	S18947001	1	オサエバネ	PRESSER SPRING, -3	
34	140407001	2	ザガネ	WASHER	
40-2	※	1	オサエクミ	PRESSER FOOT ASSY	
40-2-1	100064005	1	シメネジ3.57	SCREW, SM3.57	
40-2-2	S20118151	1	カラヌイメス	TRIMMING KNIFE	
40-2-3	062670412	1	ナベコ357-40X4	SCREW, PAN SM3.57-40X4	
40-2-4	147871001	4	オサエヒン	PIN	
40-2-5	S40358101	1	オサエMバネ	SPRING, M	
40-2-6	111105002	1	シメネジ2.38	SCREW, SM2.38	
40-2-7	S40360001	1	オサエFバネ	SPRING	
40-2-8	147932001	1	ダンネジ2.38	SHOULDER SCREW, SM2.38	
40-2-9	S40374001	1	フィンガーガード	FINGER GUARD	
			<オプションパーツ (フィーディングフット)>	<OPTION PARTS (FOR FEEDING PRESSER FOOT)>	
21-2	S18947001	1	オサエバネ	PRESSER SPRING, -3	
34	140407001	2	ザガネ	WASHER	
35	S40539001	1	オサエボウストツバ	PRESSER BAR STOPPER	
36	154574001	1	ボルト4.37	BOLT, SM4.37	
37	102571003	1	ナツト4.37	NUT, SM4.37	
38	100645003	2	ザガネ	WASHER	
39	117516001	2	ボルト4.37	BOLT, M4.37	
40-3	※	1	Fオサエクミ	F. PRESSER FOOT ASSY	
40-3-1	S40549101	1	Fオサエコグミ	F. PRESSER FOOT BOTTOM ASSY	
40-3-2	S40544101	1	Fオサエシジタイクミ	PRESSER FOOT BASE	
40-3-3	S40555001	1	オサエシジヒン	PRESSER FOOT PIN	
40-3-4	S40556001	1	オサエホジバネ	SPRING	
40-3-5	111105002	1	シメネジ2.38	SCREW, SM2.38	
40-3-6	S13085001	1	トメネジ3.18	SET SCREW, SM3.18	
40-3-7	021670202	1	ナツト2シユ3.57	NUT, 2 SM3.57	
40-3-8	105161004	1	ザガネ	WASHER	
40-3-9	S40558001	1	オサエバネ	PRESSER SPRING	
40-3-10	S40557001	1	オサエバネナツト	PRESSER SPRING NUT	
40-3-11	014680422	2	アナトメネジ4.37クホミ	SET SCREW, SOCKET (CP) SM4.37	
40-3-12	S20118151	1	カラヌイメス	TRIMMING KNIFE	
40-3-13	062670412	1	ナベコ357-40X4	SCREW, PAN SM3.57-40X4	
40-3-14	S36894000	1	フィンガーガード	FINGER GUARD	

< 013-□ , 014-□ >

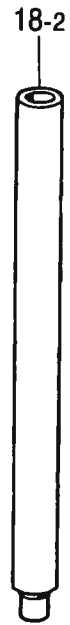
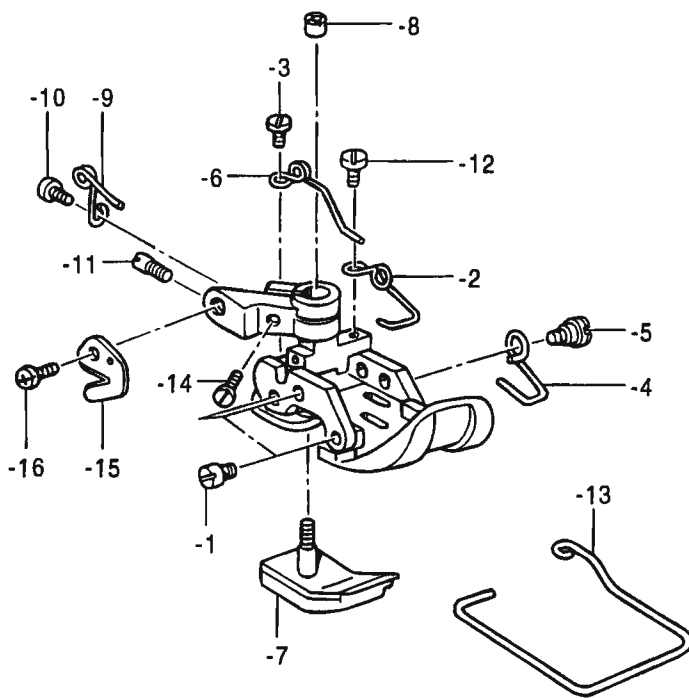

< 015-□ >

< オプションパーツ (厚物用空環対応押え) >

< OPTION PARTS (FOR CHAINING-OFF STITCH PRESSER FOOT FOR HEAVY-WEIGHT MATERIAL) >

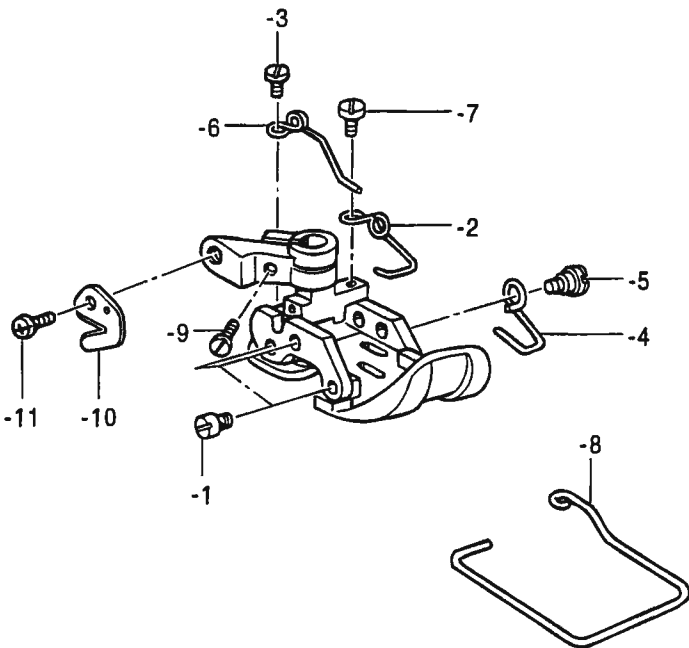

E. 押工関係 / Presser foot mechanism / Stoffdrückerfuß / Mécanisme de pied presseur / Mecanismo de la prensa tela

REF.NO.	CODE	Q'TY	ヒンメイ	NAME OF PARTS	RM
			<013-□,014-□>	<013-□,014-□>	
18-2	S44887001	1	オサエボウ	PRESSER BAR	
21-1	141728001	1	オサエバネ	PRESSER SPRING	
40-7	※	1	オサエクミ	PRESSER FOOT ASSY	
40-7-1	147871001	6	オサエピン	PIN	
40-7-2	147872001	1	オサエMバネ	SPRING	
40-7-3	S01295001	1	シメネジ2.38X3.5	SCREW, SM2.38X3.5	
40-7-4	147890001	1	オサエFバネ	SPRING	
40-7-5	147932001	1	ダンネジ2.38	SHOULDER SCREW, SM2.38	
40-7-6	147875001	1	オサエBLバネ	SPRING	
40-7-7	147876001	1	オサエBS	PRESSER FOOT, BS	
40-7-8	147877001	1	ツマミナツト3.18	NUT, SM3.18	
40-7-9	147878001	1	オサエBSバネ	SPRING	
40-7-10	062660512	1	ナベコネジ318-40X5	SCREW, PAN SM3.18-40X5	
40-7-11	147879001	1	トメネジ3.18	SET SCREW, SM3.18	
40-7-12	111105002	1	シメネジ2.38	SCREW, SM2.38	
40-7-13	151572101	1	フィンガーガード	FINGER GUARD	
40-7-14	100064005	1	シメネジ3.57	SCREW, SM3.57	
40-7-15	S20118151	1	カラヌイメス	TRIMMING KNIFE	
40-7-16	062670412	1	ナベコ357-40X4	SCREW, PAN SM3.57-40X4	
			<015-□>	<015-□>	
			<オプションパーツ (厚物用空環対応押え)>	<OPTION PARTS(CHAINING-OFF STITCH PRESSER FOOT FOR HEAVY MATERIALS)>	
18-2	S44887001	1	オサエボウ	PRESSER BAR	
21-1	141728001	1	オサエバネ	PRESSER SPRING	
40-18	※	1	オサエクミ	PRESSER FOOT ASSY	
40-18-1	147871001	6	オサエピン	PIN	
40-18-2	147872001	1	オサエMバネ	SPRING	
40-18-3	S01295001	1	シメネジ2.38X3.5	SCREW, SM2.38X3.5	
40-18-4	147890001	1	オサエFバネ	SPRING	
40-18-5	147932001	1	ダンネジ2.38	SHOULDER SCREW, SM2.38	
40-18-6	147875001	1	オサエBLバネ	SPRING	
40-18-7	111105002	1	シメネジ2.38	SCREW, SM2.38	
40-18-8	151572101	1	フィンガーガード	FINGER GUARD	
40-18-9	100064005	1	シメネジ3.57	SCREW, SM3.57	
40-18-10	S20118151	1	カラヌイメス	TRIMMING KNIFE	
40-18-11	062670412	1	ナベコ357-40X4	SCREW, PAN SM3.57-40X4	

F. 送り関係 / Feed mechanism / Transportvorrichtung / Mécanisme de l'entraînement / Mecanismo de la alimentación

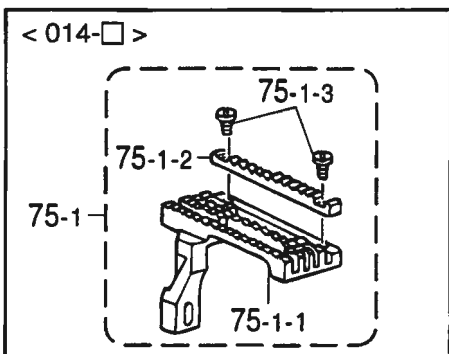
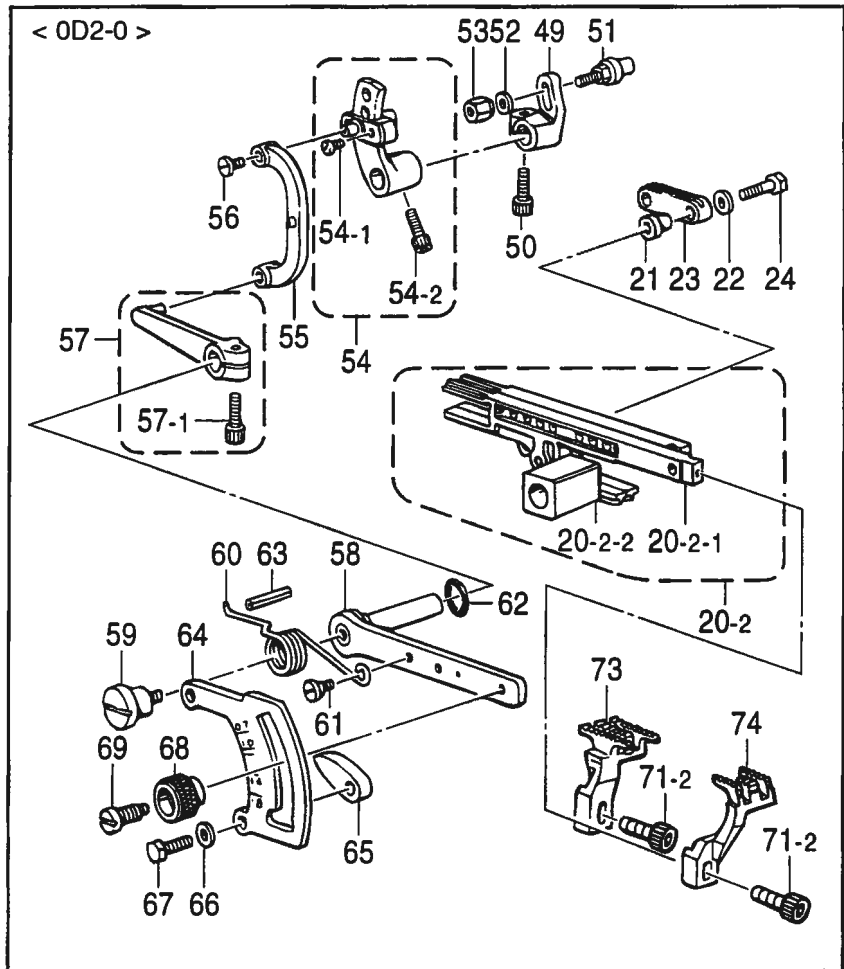
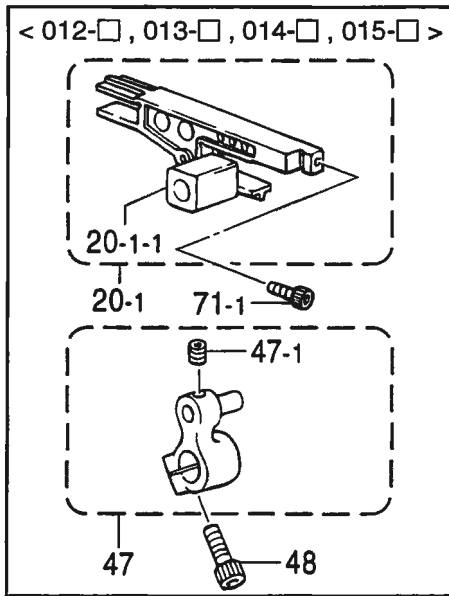
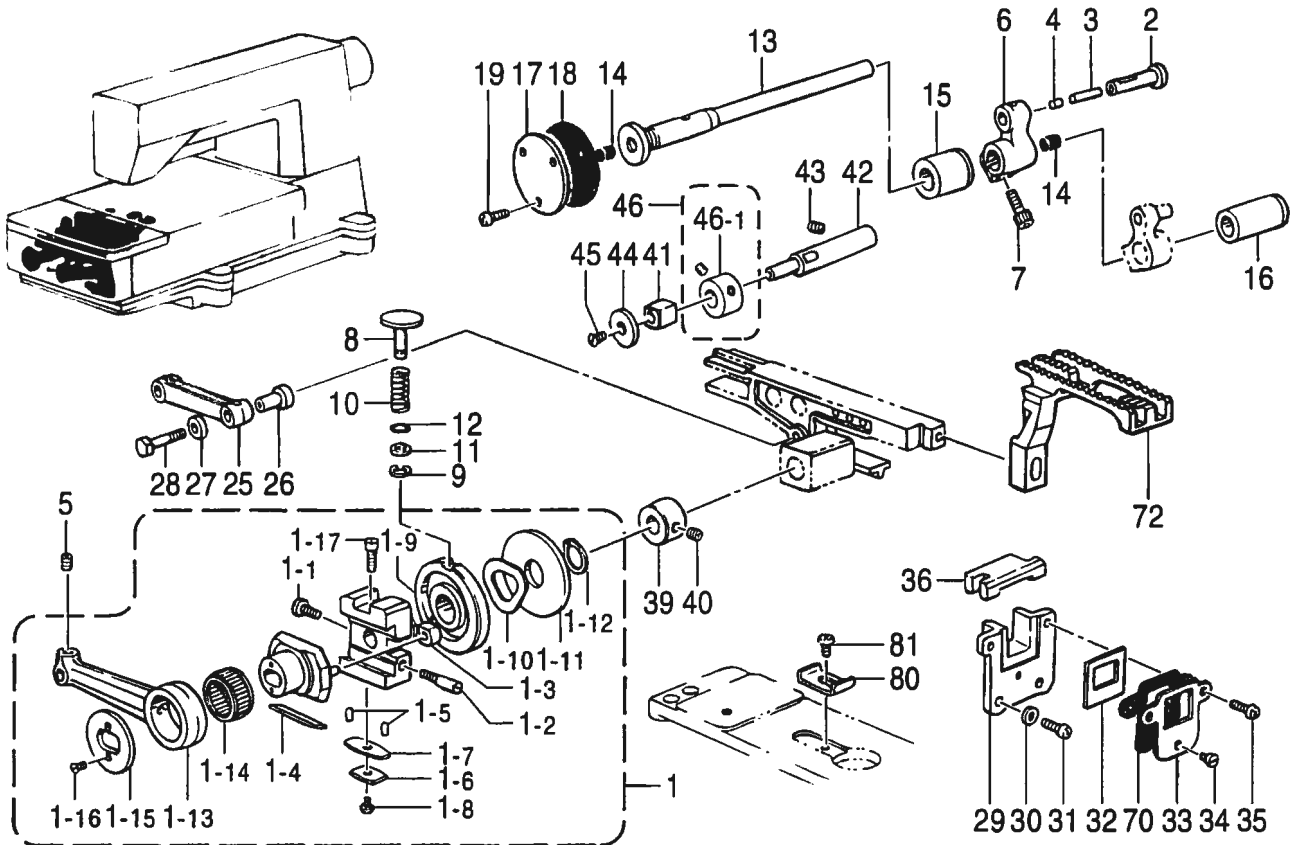

F. 送り関係 / Feed mechanism / Transportvorrichtung / Mécanisme de l'entraînement / Mecanismo de la alimentación

REF.NO.	CODE	Q'TY	ヒンメイ	NAME OF PARTS	RM
1	146528102	1	ヘンシンリンクミ	ECCENTRIC WHEEL ASSY	
1-1	S16498001	1	シメネジ4.37	SCREW, SM4.37	
1-2	145663001	1	トメネジ4.37	SET SCREW, SM4.37	
1-3	140165001	1	チヨウセツピンカワコマ	SLIDE BLOCK	
1-4	146401001	1	ジブ	GIB	
1-5	146402001	2	ジブオサエピン	PIN	
1-6	146403001	1	ジブオサエイタバネS	PLATE SPRING, S	
1-7	146404001	1	ジブオサエイタバネL	PLATE SPRING, L	
1-8	062660512	1	ナベコネジ318-40X5	SCREW, PAN SM3.18-40X5	
1-9	144053001	1	ヘンシンチヨウセツカムクミ	ECCENTRIC WHEEL ADJ. CAM ASSY	
1-10	144055001	1	ナミバネ	SPRING, WAVE	
1-11	146529001	1	ザガネ	WASHER	
1-12	048150143	1	トメワジクヨウC15	RETAINING RING, C15	
1-13	146530001	1	オクリロツド	FEED ROD	
1-14	146531001	1	ニードルジクウケ20	NEEDLE ROLLER BEARING 20	
1-15	140176001	1	オクリロツドオサエイタ	FEED ROD PRESSER PLATE	
1-16	117517003	2	サラネジ2.38	SCREW, FLAT SM2.38	
1-17	100025002	2	シメネジ4.76	SCREW, SM4.76	
2	146532001	1	オクリロツドピン	PIN	
3	147318000	1	ヒン	PIN	
4	140326009	1	ゴムセン3.3	RUBBER CAP, 3.3	
5	100251001	1	トメネジ6.35	SET SCREW, SM6.35	
6	146533001	1	オクリウデ	FEED ARM	
7	018771432	1	アナボルト635-40X14	BOLT, SOCKET SM6.35-40X14	
8	S08870001	1	プツシユボタン	PUSH BUTTON	
9	048040342	1	トメワE4	RETAINING RING, E4	
10	S08871001	1	ボタンジクバネ	SPRING	
11	153484001	1	ザガネ4.76	WASHER, PLAIN 4.76	
12	081003670	1	OリングPW3	O RING, PW3	
13	146538101	1	オクリジク	FEED SHAFT	
14	140327001	2	ゴムセン6.3	RUBBER CAP, 6.3	
15	146539000	1	オクリジクメタルL	FEED SHAFT BUSH, L	
16	146540000	1	オクリジクメタルR	FEED SHAFT BUSH (R)	
17	155144001	1	オクリジクメタルLフタ	FEED SHAFT BUSH (L) CAP	
18	155145000	1	パツキン	PACKING	
19	062670812	3	ナベコ3.57-40X8	SCREW, PAN SM3.57-40X8	
25	146554001	1	サドウオクリリンク	DIFFERENTIAL FEED LINK	
26	146555001	1	サドウオクリリンクブシユ	DIFFERENTIAL FEED LINK BUSH	
27	S23359001	1	ザガネ	WASHER	
28	140217001	1	オクリリンクジクL	FEED LINK SHAFT (L)	
29	155151000	1	オクリダイアンナイ	FEED BAR GUIDE	
30	100645003	2	ザガネ	WASHER	
31	062681012	2	ナベコ437-40X10	SCREW, PAN SM4.37-40X10	
32	155177100	1	ボウジンイタ	FRAGMENT PROTECTOR PLATE	
33	155178001	1	ボウジンイタササエ	FRAGMENT PROTECTOR SUPPORT	
34	S39086001	1	ナベコ357-40X3.5	SCREW, PAN SM3.57-40X3.5	
35	062681012	2	ナベコ437-40X10	SCREW, PAN SM4.37-40X10	
36	S08876000	1	オクリダイボウジンタイ	FEED BAR FRAGMENT PROTECTOR BASE	
39	146741000	1	セツトカラー	SET SCREW COLLAR	
40	101706001	1	トメネジ6.35	SET SCREW, SM6.35	
41	146547000	1	オクリダイカクゴマ	FEED BAR SLIDE BLOCK	
42	146548101	1	オクリダイカクゴマジク	FEED BAR SLIDE BLOCK SHAFT	
43	014780622	1	アナトメネジ6.35クボミ	SET SCREW, SOCKET (CP) SM6.35	
44	S08877001	1	オクリダイカクゴマアテイタ	SLIDE PLATE	
45	107272002	1	サラネジ4.37	SCREW, FLAT SM4.37	
46	S03704002	1	セツトカラークミ	SET SCREW COLLAR ASSY	
46-1	014770622	2	アナトメネジ6.35クボミ	SET SCREW, SOCKET (CP) SM6.35	
70	S08467000	1	パツキン	PACKING	
72	※	1	オクリバ	FEED DOG	
80	S16249001	1	プツシユボタンストツパ	PUSH BUTTON STOPPER	
81	060680512	1	バインド437-40X5	SCREW, BIND SM4.37-40X5	

F. 送り関係 / Feed mechanism / Transportvorrichtung / Mécanisme de l'entraînement / Mecanismo de la alimentación

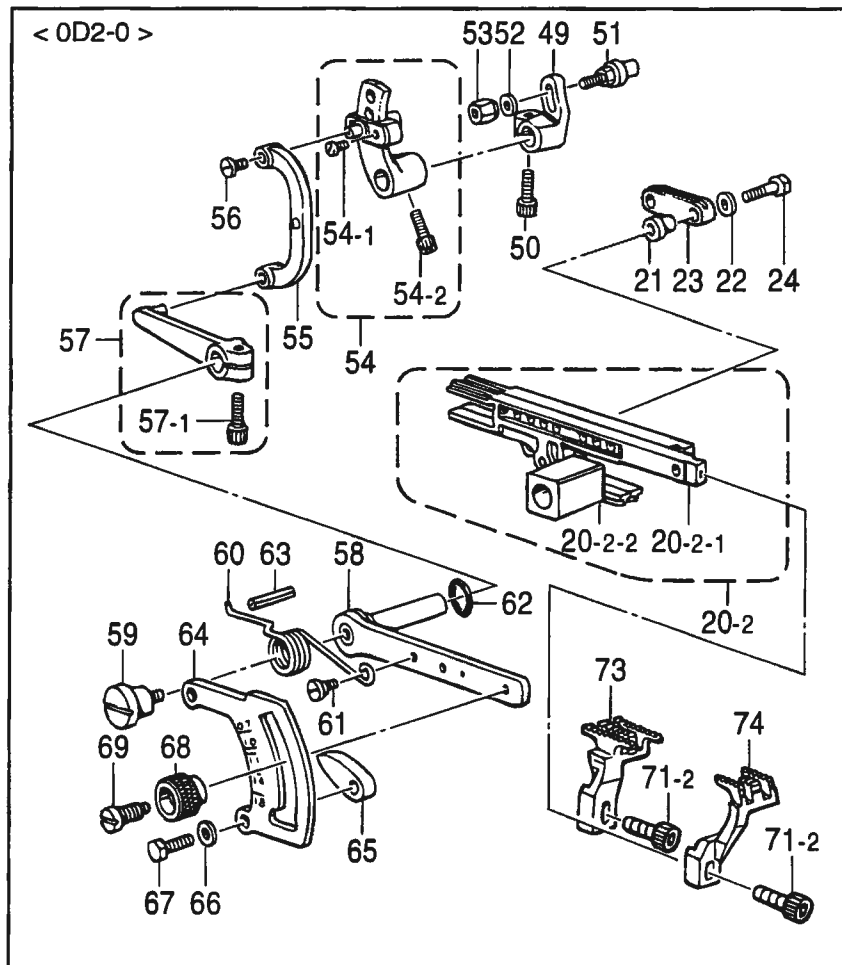
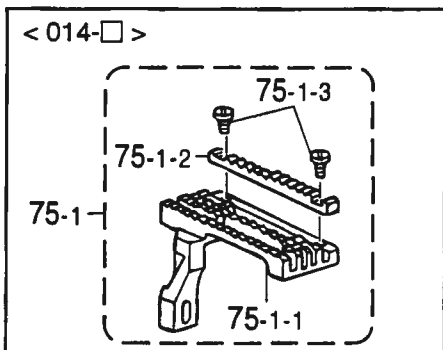
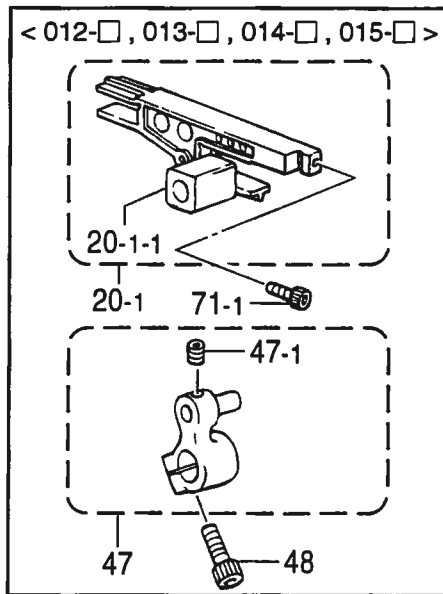
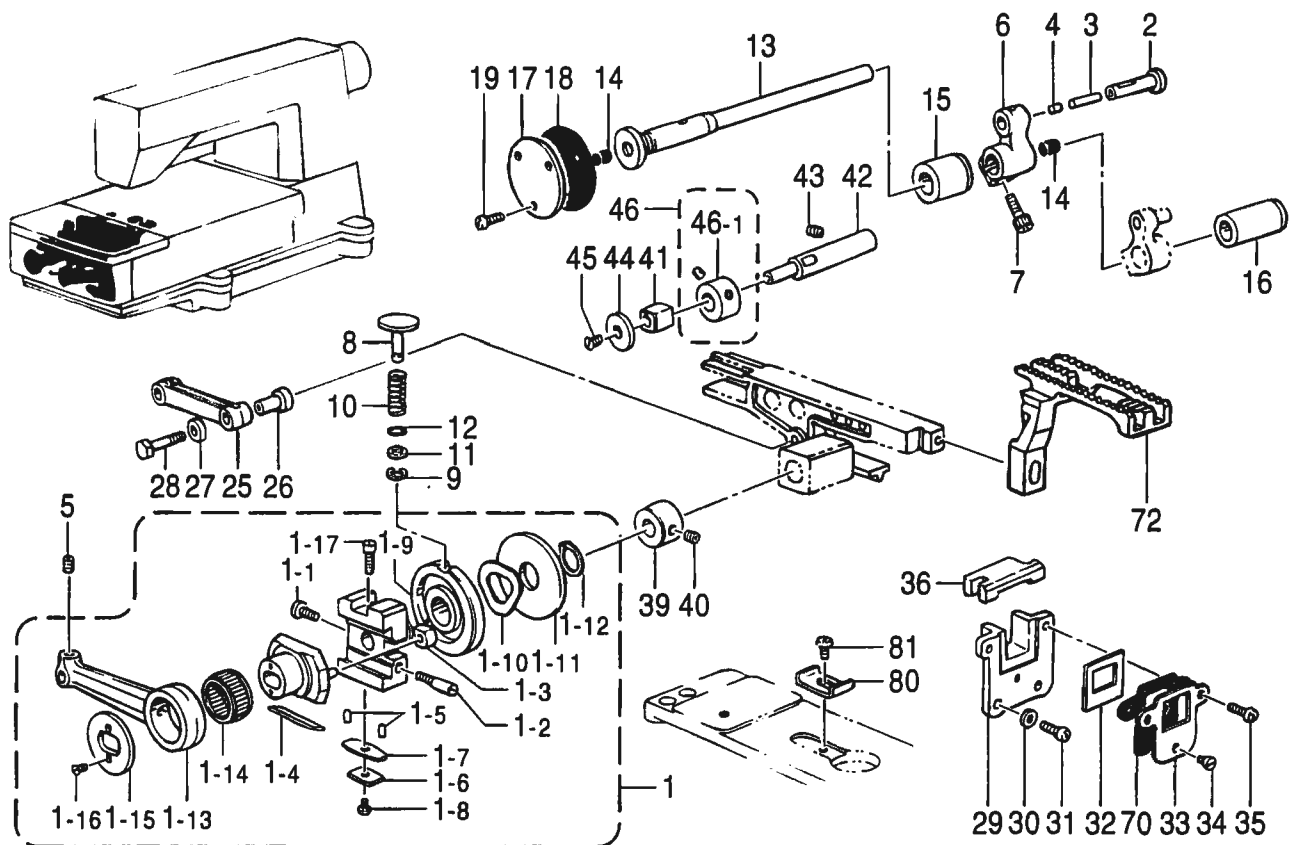

F. 送り関係 / Feed mechanism / Transportvorrichtung / Mécanisme de l'entraînement / Mecanismo de la alimentación

REF.NO.	CODE	Q'TY	ヒンメイ	NAME OF PARTS	RM
			<012-□, 013-□, 014-□, 015-□>	<012-□, 013-□, 014-□, 015-□>	
20-1	S40562001	1	オクリダイカクゴマクミ	FEED BAR SLIDE BLOCK ASSY	
20-1-1	146544000	1	ジヨウゲオクリカクコマ	FEED LIFTING SLIDE BLOCK	
47	S40559001	1	オクリウデクミ	FEED ARM ASSY	
47-1	014770622	1	アナトメネジ6.35クボミ	SET SCREW, SOCKET (CP) SM6.35	
48	018771432	1	アナボルト635-40X14	BOLT, SOCKET SM6.35-40X14	
71-1	018501022	1	アナボルト5X10	BOLT, SOCKET M5X10	
			<014-□>	<014-□>	
75-1	※	1	オクリバクミ	FEED DOG ASSY	
75-1-1	S44902001	1	オクリバ	FEED DOG	
75-1-2	S44903001	1	トリツケバ	SUB FEED DOG	
75-1-3	147880001	2	シメネジ1.98	SCREW, SM1.98	
			<0D2-0>	<0D2-0>	
20-2	S08872001	1	オクリダイカクゴマクミ	FEED BAR SLIDE BLOCK ASSY	
20-2-1	S08873001	1	オクリダイクミ	FEED BRACKET ASSY	
20-2-2	146544000	1	ジヨウゲオクリカクコマ	FEED LIFTING SLIDE BLOCK	
21	140207001	1	シュオクリリンクブシュ	MAIN FEED LINK BUSH	
22	S23359001	1	ザガネ	WASHER	
23	140209001	1	シュオクリリンク	MAIN FEED LINK	
24	140210001	1	シュオクリリンクジクS	MAIN FEED LINK SHAFT (S)	
49	140205001	1	シュオクリウデ	MAIN FEED ARM	
50	018771432	1	アナボルト635-40X14	BOLT, SOCKET SM6.35-40X14	
51	143564001	1	シュオクリジク	MAIN FEED SHAFT	
52	113431002	1	ザガネ	WASHER	
53	143565001	1	ナツト4.76	NUT, SM4.76	
54	S08878001	1	サドウオクリウデクミ	DIFFERENTIAL FEED ARM ASSY	
54-1	062660712	2	ナベコ318-40X7	SCREW, PAN SM3.18-40X7	
54-2	018771432	1	アナボルト635-40X14	BOLT, SOCKET SM6.35-40X14	
55	146556001	1	サドウリンク	DIFFERENTIAL FEED ADJUST LINK	
56	148834001	1	シメネジ3.57	SCREW, M3.57	
57	S08879001	1	リンクレバーネジツキ	DIFFERENTIAL FEED LINK LEVER ASSY	
57-1	018771432	1	アナボルト635-40X14	BOLT, SOCKET SM6.35-40X14	
58	S08880001	1	サドウチヨウセツレバー	DIFFERENTIAL FEED ADJUST LEVER	
59	146559001	1	ダンネジ5.56	STUD SCREW, M5.56	
60	146560101	1	レバーバネ	LEVER SPRING	
61	100294002	1	ダンネジ4.76	SHOULDER SCREW, SM4.76	
62	109203001	1	Oリング	O RING	
63	047502242	1	スフリングヒンAW5	PIN, SPRING ROLL AW5	
64	S08881101	1	サドウリヨウメモリイタ	DIFFERENTIAL STITCH CONTROL	
65	146563001	2	チヨウセツレバーストツハ	STOPPER, ADJUSTING LEVER STITCH CONTROL	
66	025770232	2	ヒラザガネチユウ6.35	WASHER, PLAIN M 6.35	
67	017781412	2	ボルト6.35X14	BOLT, SM6.35X14	
68	155175051	1	セツトネジツマミ	SET SCREW, KNOB	
69	155176001	1	セツトネジ	SET SCREW	
71-2	154965001	2	アナボルト3.57X8	BOLT, SOCKET SM3.57X8	
73	※	1	シュオクリバ	MAIN FEED DOG	
74	※	1	サドウオクリバ	DIFFERENTIAL FEED DOG	
			<オプションパーツ (一本針薄物用細目)>	<OPTION PARTS(SINGLE NEEDLE, THIN MATERIALS, EXTRA FINE FEED DOG)>	
72	※	1	オクリバ	FEED DOG	



G. プーラ装置関係 / Puller device mechanism / Ziehvorrichtung / Mécanisme due puller / Mecanismo del dispositivo de arrastre

<□/ RP1 >

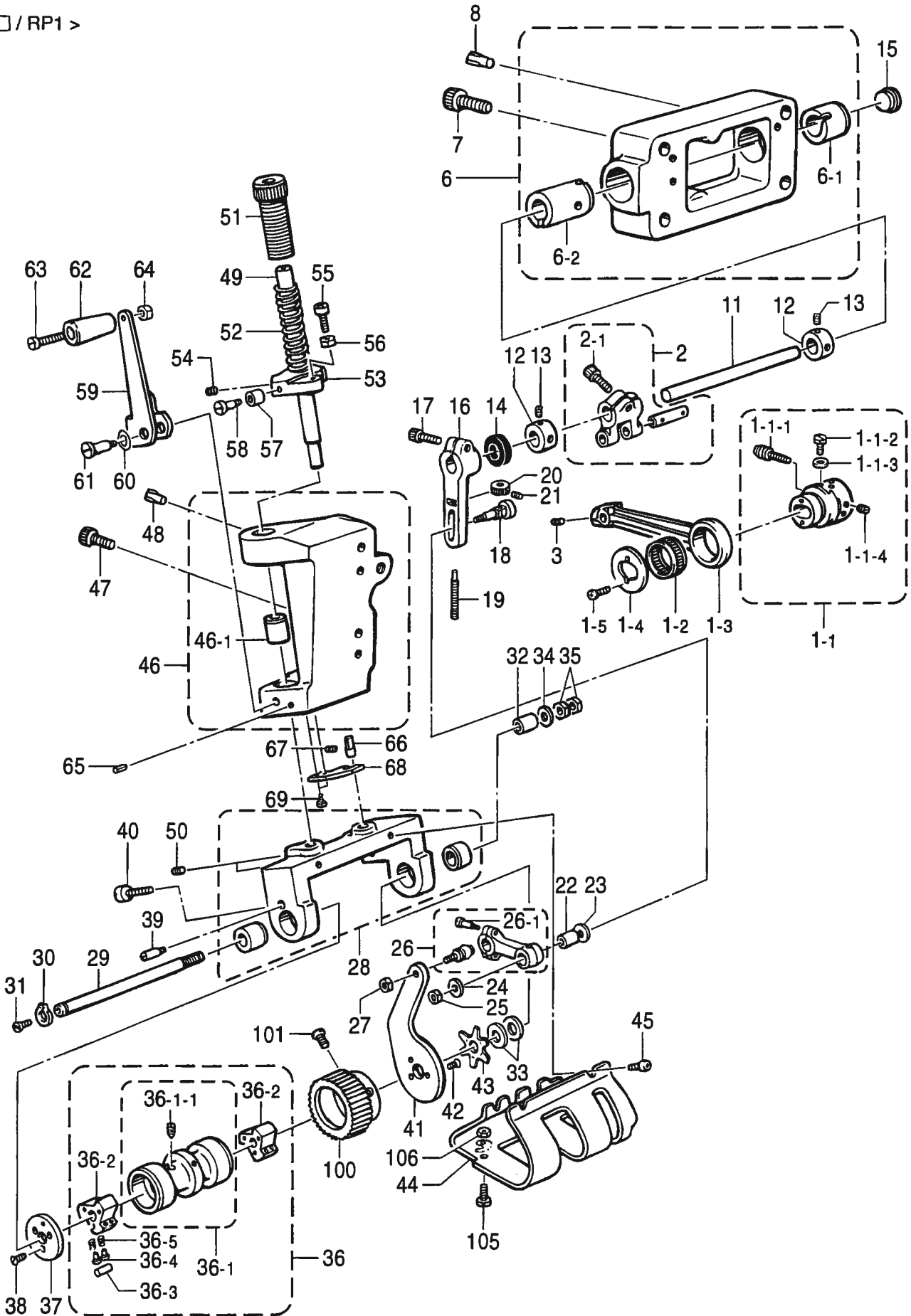

G. プーラ装置関係 / Puller device mechanism / Ziehvorrichtung / Mécanisme due puller /  
Mecanismo del dispositivo de arrastre

REF.NO.	CODE	Q'TY	ヒンメイ	NAME OF PARTS	RM
			<□/RP1>	<□/RP1>	
1	S13414201	1	プーラハンシンリンロツクミ	PULLER ECCENTRIC WHEEL ROD ASSY	
1-1	S12913201	1	プーラハンシンリンクミ	PULLER ECCENTRIC WHEEL ASSY	
1-1-1	113644001	1	ハンシンリンチヨウセツネシ	ADJUSTING SCREW	
1-1-2	144075001	2	ボルト3.57	BOLT, SM3.57	
1-1-3	105161004	2	ザガネ	WASHER	
1-1-4	014760622	3	アナトメネジ5.95	SET SCREW, SOCKET SM5.95	
1-2	S12915001	1	ニードルジクウケ25	NEEDLE ROLLER BEARING 25	
1-3	S12916001	1	プーラロツド	PULLER ROD	
1-4	S12821001	1	レンカンオサエ	CONNECTING ROD PRESSER	
1-5	062630612	2	ナベコ238-56X6	SCREW, PAN SM2.38-56X6	
2	S17773001	1	クランクジクウデピンクミ	CRANK LEVER PIN ASSY	
2-1	018771432	1	アナボルト635-40X14	BOLT, SOCKET SM6.35-40X14	
3	014770622	1	アナトメネジ6.35クボミ	SET SCREW, SOCKET (CP) SM6.35	
6	S28250001	1	プーラブラケットRクミ	PULLER BRACKET (R) ASSY	
6-1	148120000	1	クランクジクメタルR	CRANK SHAFT BUSH (R)	
6-2	S28252000	1	プーラクドウジクメタルL	PULLER DRIVING SHAFT BUSH (L)	
7	018063022	4	アナボルト6X30	BOLT, SOCKET M6X30	
8	117608001	2	ミゾツキピン	DOWEL PIN	
11	S28253001	1	プーラクドウジク	PULLER DRIVING SHAFT	
12	140092001	2	セツトカラー	SET SCREW COLLAR	
13	014680422	4	アナトメネジ4.37クボミ	SET SCREW, SOCKET (CP) SM4.37	
14	S12918000	1	ダストシール	DUST SEAL	
15	159150009	1	ゴムセン20.5	RUBBER CAP, 20.5	
16	S12919001	1	プーラクドウレバー	PULLER DRIVING LEVER	
17	018061622	1	アナボルト6X16	BOLT, SOCKET M6X16	
18	S12920001	1	プーラレンカンジク	PULLER CONNECTING SHAFT	
19	S12921001	1	チヨウセツネジ	ADJUSTING SCREW	
20	S12922001	1	ツマミ	KNOB	
21	148294001	1	アナトメネジ3.57クボミ	SET SCREW, SOCKET (CP) SM3.57	
22	S12923001	1	レンカンスリーブ	CONNECTING ROD SLEEVE	
23	156265001	1	ザガネ	WASHER, PLAIN 6	
24	107453001	1	ザガネ	WASHER	
25	110140001	1	ナツト5.56	NUT, M5.56	
26	S12924001	1	プーラレンカンクミ	PULLER CONNECTING ROD ASSY	
26-1	100526003	2	ダンネジ3.57	SHOULDER SCREW, SM3.57	
27	110140001	1	ナツト5.56	NUT, M5.56	
28	S28254001	1	プーラフレームクミ	PULLER FRAME ASSY	
29	S28256001	1	プーラジク	PULLER SHAFT	
30	048090142	1	トメワジクヨウC9	RETAINING RING, C9	
31	107272002	1	サラネジ4.37	SCREW, FLAT SM4.37	
32	S12933001	1	プーラブツシュ	PULLER BUSH	
33	S02556001	2	ザガネ	WASHER	
34	107153001	1	ザガネ	WASHER	
35	105812003	2	ナツト7.94	NUT, SM7.94	
36	S12934101	1	プーラクラツチクミ	PULLER CLUTCH ASSY	
36-1	S13415101	1	プーラクラツチシユウクミ	PULLER CLUTCH SHOE ASSY	
36-1-1	118853001	1	アナトメネジ5.95	SET SCREW, SOCKET SM5.95	
36-2	S09039001	2	クラツチツメ	CLUTCH CLAW	
36-3	150604101	6	コロ	ROLLER	
36-4	150605001	12	クラツチピン	CLUTCH PIN	
36-5	S12900001	12	クラツチバネ	SPRING	
37	S12936001	1	クラツチイタ	CLUTCH PLATE	
38	106128004	3	サラネジ3.57	SCREW, FLAT SM3.57	
39	S12937101	1	スタツド	STUD	
40	121007001	1	アタマツキトメネジ4.37	SET SCREW, SM4.37	
41	S28334001	1	クラツチレバー	CLUTCH LEVER	
42	106128004	3	サラネジ3.57	SCREW, FLAT SM3.57	
43	S12939001	1	ホシガタバネ	SPRING	

G. プーラ装置関係 / Puller device mechanism / Ziehvorrichtung / Mécanisme due puller / Mecanismo del dispositivo de arrastre

< □ / RP1 >

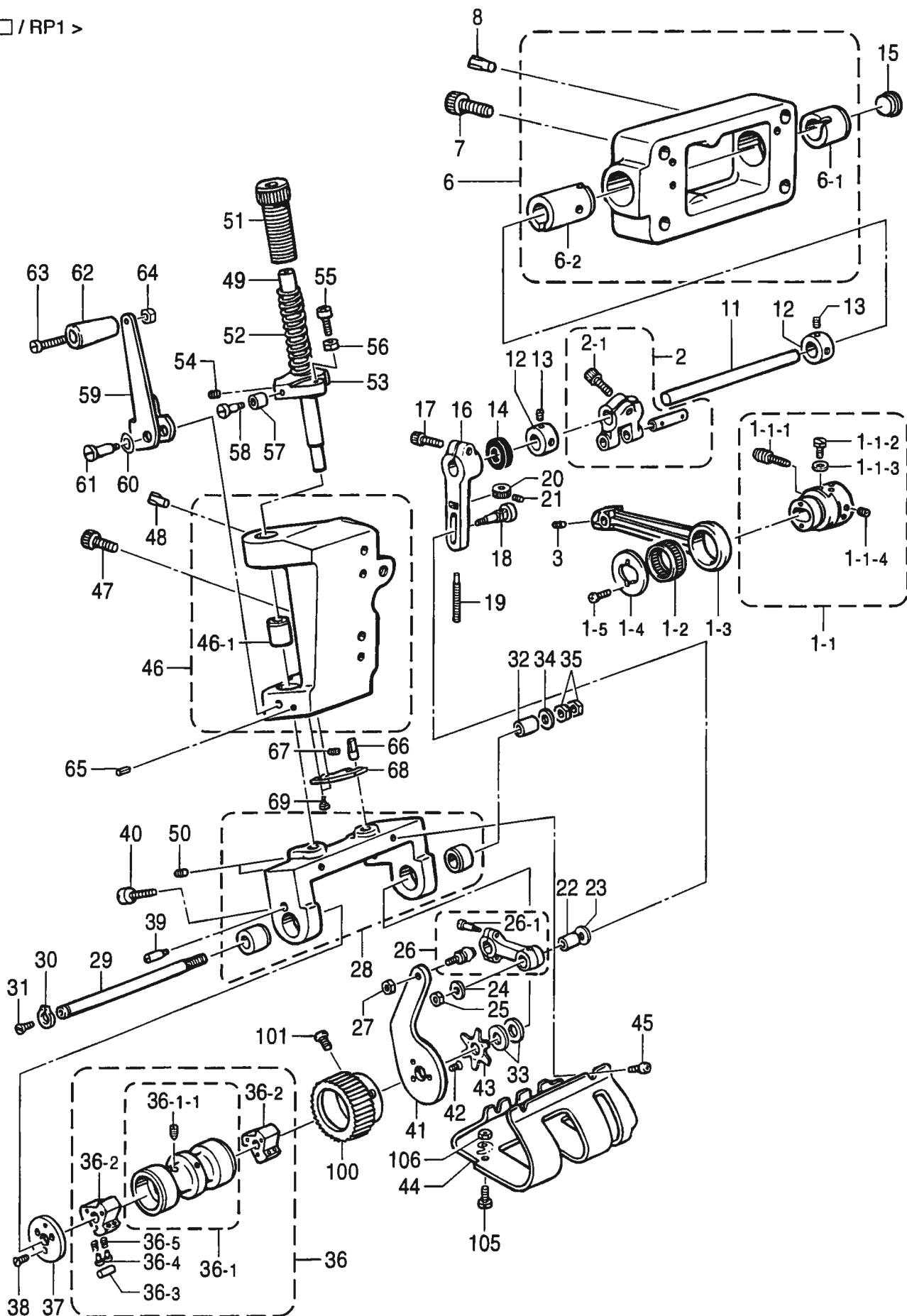

G. プーラ装置関係 / Puller device mechanism / Ziehvorrichtung / Mécanisme due puller /  
Mecanismo del dispositivo de arrastre

REF.NO.	CODE	Q'TY	ヒンメイ	NAME OF PARTS	RM
44	S44906101	1	プーラーガード	PULLER GUARD	
45	062680612	3	ナベコ4.37-40X6	SCREW, PAN SM4.37-40X6	
46	S28261101	1	プーラブラケットLクミ	PULLER BRACKET (L) ASSY	
46-1	S12858000	1	リテーナシクメタルF	RETAINER SHAFT BUSH (F)	
47	018061622	2	アナボルト6X16	BOLT, SOCKET M6X16	
48	117608001	2	ミゾツキピン	DOWEL PIN	
49	S12942001	1	プーラオサエボウ	PULLER PRESSER BAR	
50	014760622	2	アナトメネジ5.95	SET SCREW, SOCKET SM5.95	
51	S12943001	1	プーラアツチヨウセツネジ	ADJUST SCREW	
52	S28263001	1	プーラオサエバネ	PULLER SPRING	
53	S28264001	1	プーラオサエボウダキ	PULLER PRESSER BAR CLAMP	
54	014770622	1	アナトメネジ6.35クボミ	SET SCREW, SOCKET (CP) SM6.35	
55	062682012	1	ナベコ437-40X20	SCREW, PAN SM4.37-40X20	
56	105234003	1	ナツト4.37	NUT, SM4.37	
57	110167001	1	コロ	ROLLER	
58	110168001	1	コロジク	ROLLER SHAFT	
59	S12946001	1	プーラアゲレバー	PULLER LIFTING LEVER	
60	109239001	1	ナミバネザガネ	WASHER, WAVE SPRING	
61	S28333001	1	ダンネジ5.95	STUD SCREW, M5.95	
62	159093009	1	ハンドル	HANDLE	
63	112700001	1	シメネジ5.95	SCREW, SM5.95	
64	106588003	1	ナツト5.95	NUT, SM5.95	
65	047401442	1	スプリングピンAW4	PIN, SPRING ROLL AW4	
66	S28265001	1	アンナイジク	GUIDE SHAFT	
67	014680422	1	アナトメネジ4.37クボミ	SET SCREW, SOCKET (CP) SM4.37	
68	S28266001	1	アンナイイタ	GUIDE PLATE	
69	017681012	2	ボルト4.37X10	BOLT, SM4.37X10	
100	S44907001	1	スチールギヤ65	STEEL GEAR (65)	
101	102538002	3	サラネジ3.57	SCREW, FLAT SM3.57	
105	100257010	1	シメネジ3.57	SCREW, SM3.57X6	
106	021670102	1	ナツト1シユ3.57	NUT, 1 SM3.57	

H. 下軸関係 / Lower shaft mechanism / Untere Welle / Mécanisme de l'arbre inférieur / Mecanismo del eje inferior

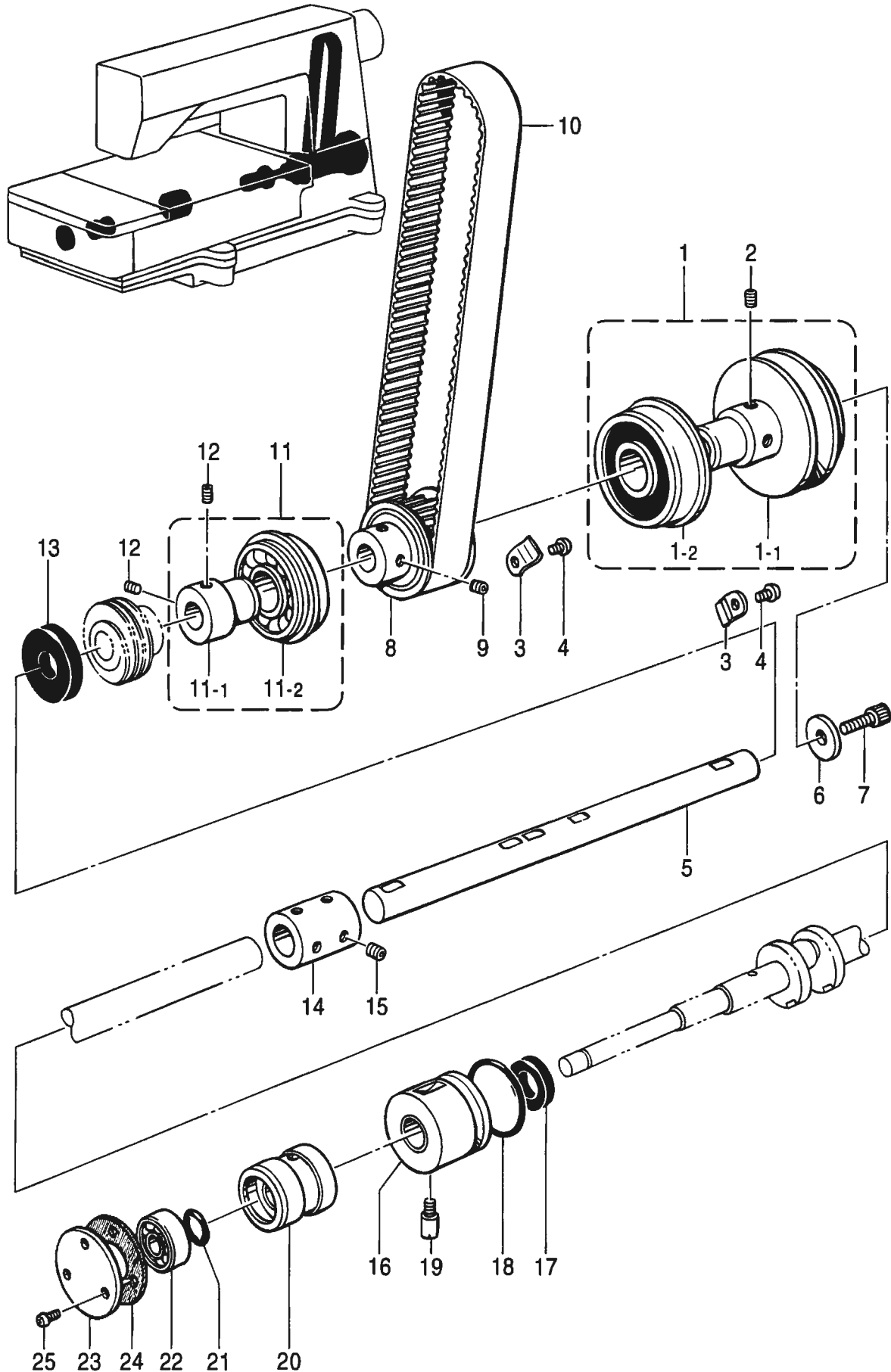

H. 下軸関係 / Lower shaft mechanism / Untere Welle / Mécanisme de l'arbre inférieur /  
Mecanismo del eje inferior

REF.NO.	CODE	Q'TY	ヒンメイ	NAME OF PARTS	RM
1	S08889101	1	Vベルトフーリクミ	V-BELT PULLEY ASSY	
1-1	S08890001	1	Vベルトプーリ	V-BELT PULLEY	
1-2	S14622001	1	タマジクウケ6304VV	BALL BEARING, 6304VV	
2	014780622	2	アナトメネジ6.35クボミ	SET SCREW, SOCKET (CP) SM6.35	
3	153734001	2	アームササエイタバネ	PLATE SPRING	
4	062680612	2	ナベコ4.37-40X6	SCREW, PAN SM4.37-40X6	
5	S08891001	1	シタジクR	LOWER SHAFT (R)	
6	154886001	1	ザガネ	WASHER	
7	018771432	1	アナボルト635-40X14	BOLT, SOCKET SM6.35-40X14	
8	S08892001	1	タイミングプーリDクミ	TIMING PULLEY (D) ASSY	
9	014770622	2	アナトメネジ6.35クボミ	SET SCREW, SOCKET (CP) SM6.35	
10	S08895002	1	タイミングベルト	TIMING BELT	
11	S08896101	1	タマジクウケクミ	BALL BEARING ASSY	
11-1	S08897001	1	タマジクウケブシユ	BALL BEARING BUSH	
11-2	S14623001	1	タマジクウケ6204DV	BALL BEARING, 6204DV	
12	014770622	2	アナトメネジ6.35クボミ	SET SCREW, SOCKET (CP) SM6.35	
13	S08898000	1	オイルシール	OIL SEAL	
14	S08899001	1	ジクツギテ	SHAFT JOINT	
15	014770622	4	アナトメネジ6.35クボミ	SET SCREW, SOCKET (CP) SM6.35	
16	S08900000	1	クランクジクメタルRクミ	LOWER SHAFT BUSH (R) ASSY	
17	S08903000	1	ダストシール	DUST SEAL	
18	081032870	1	OリングS32	O RING, S32	
19	S08967001	1	シメネジ4.76	SCREW, SM4.76	
20	S08904000	1	クランクジクメタルLクミ	CRANK SHAFT BUSH (L) ASSY	
21	114294001	1	Oリング	O RING	
22	072600000	1	タマジクウケ6000	BALL BEARING, 6000	
23	143311001	1	ベアリングフタ	BEARING COVER	
24	143312000	1	ベアリングフタパツキン	BEARING COVER PACKING	
25	062670812	3	ナベコ3.57-40X8	SCREW, PAN SM3.57-40X8	

J. ルーパー関係 / Looper mechanism / Greifer / Mécanisme des griffes / Mecanismo del Presilladora

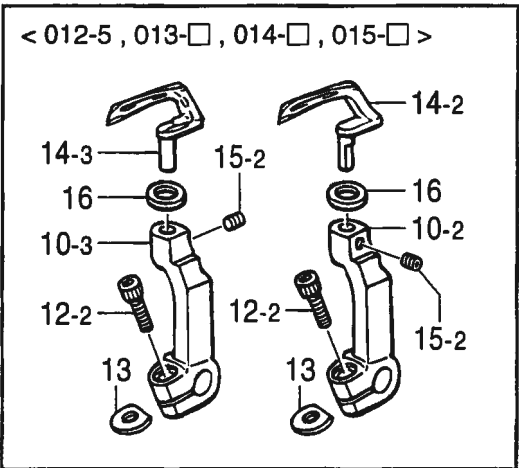
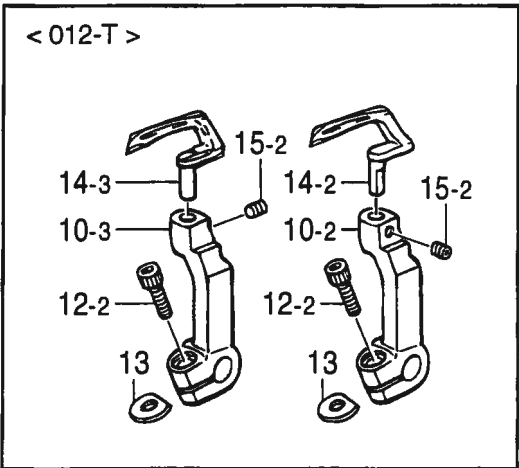
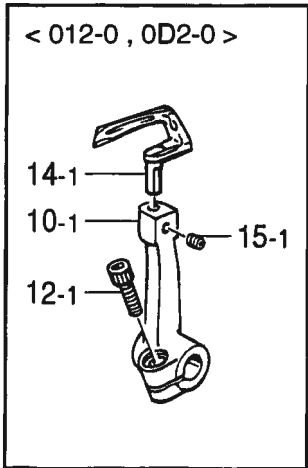
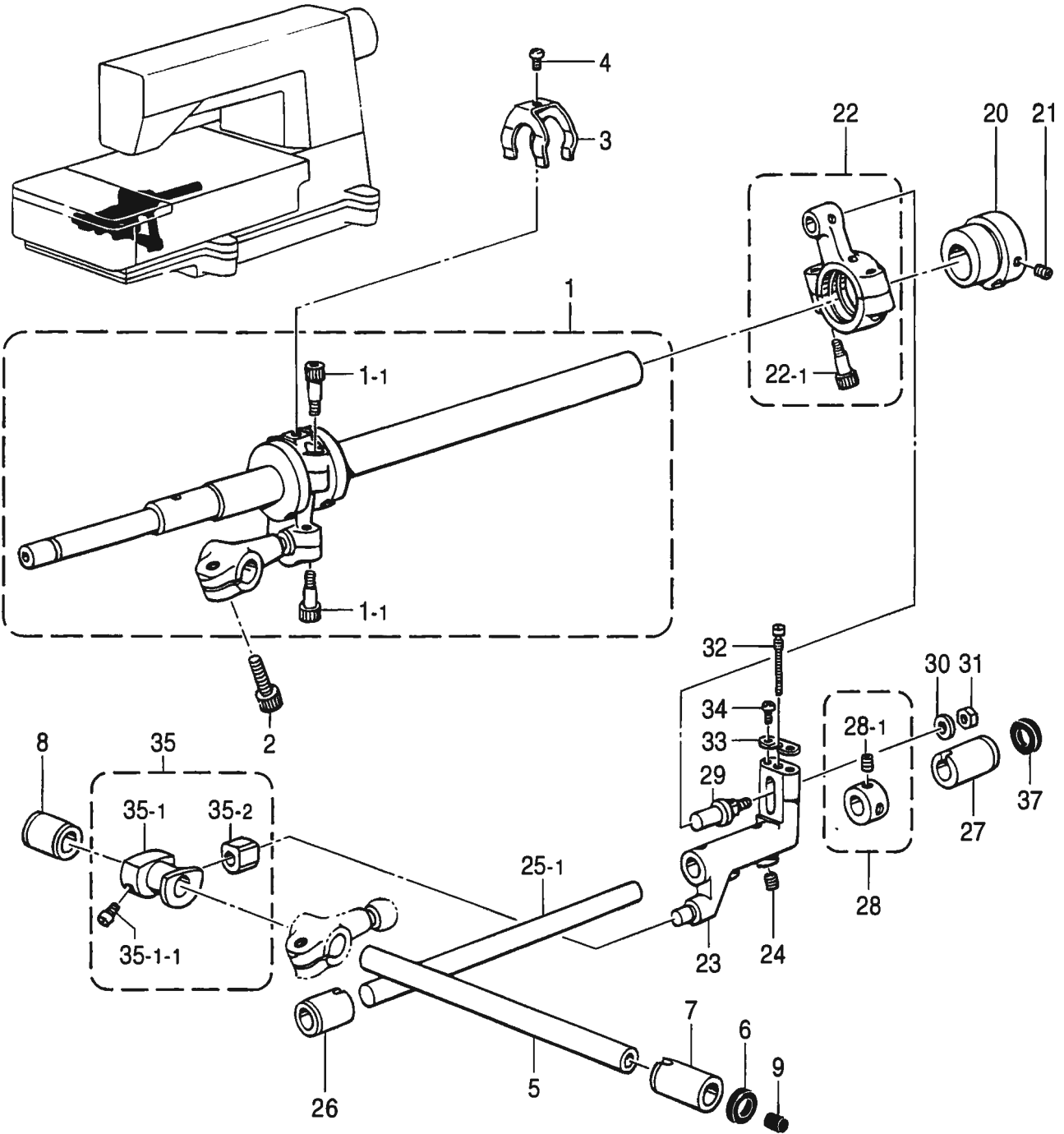

J. ルーパー関係 / Looper mechanism / Greifer / Mécanisme des griffes / Mecanismo del presilladora

REF.NO.	CODE	Q'TY	ヒンメイ	NAME OF PARTS	RM
1	S40567001	1	ルーバクラックジククミ	LOOPER CRANK SHAFT	
1-1	148425001	4	アナボルト4.37X14	BOLT, SOCKET SM4.37X14	
2	018771432	1	アナボルト635-40X14	BOLT, SOCKET SM6.35-40X14	
3	110704001	1	ウワルーハロツドフレドメ	LOOPER CONNECTING ROD STOPPER	
4	062660412	1	ナベコ318-40X4	SCREW, PAN SM3.18-40X4	
5	S40977001	1	ルーハジク	LOOPER SHAFT	
6	155539000	1	ダストシール	DUST SEAL	
7	S08770000	1	ジクメタル	SHAFT BUSH	
8	S08911000	1	ルーバジクメタルB	LOOPER SHAFT BUSHING (B)	
9	140327001	1	ゴムセン6.3	RUBBER CAP, 6.3	
20	S08914001	1	ゼンゴヘンシンリン	LONGITUDINAL ECCENTRIC CAM	
21	014680622	2	アナトメネジ4.37クボミ	SET SCREW, SOCKET (CP) SM4.37	
22	146624101	1	ゼンゴロツドクミ	LONGITUDINAL FEED ROD ASSY	
22-1	148425001	2	アナボルト4.37X14	BOLT, SOCKET SM4.37X14	
23	S08915001	1	ゼンゴレバー	LONGITUDINAL LEVER	
24	014770622	2	アナトメネジ6.35クボミ	SET SCREW, SOCKET (CP) SM6.35	
25-1	S11588001	1	ゼンゴレバークミ	LONGITUDINAL FEED SHAFT	
26	S08917000	1	レバークミメタルL	LONGITUDINAL FEED SHAFT BUSH (L)	
27	S08754000	1	ハリウケBジクメタルR	KNIFE DRIVING SHAFT BUSH (R)	
28	S03704002	1	セツトカラークミ	SET SCREW COLLAR ASSY	
28-1	014770622	2	アナトメネジ6.35クボミ	SET SCREW, SOCKET (CP) SM6.35	
29	S08918001	1	ゼンゴロツドピン	PIN	
30	148847001	1	ザガネ	WASHER, PLAIN 4.76	
31	110161006	1	ナツト4.76	NUT, SM4.76	
32	S08919001	1	ヘンシンチヨウセツネジ	ADJUST SCREW	
33	S08920001	1	ヘンシントメイタ	ECCENTRIC WHEEL STOPPER PLATE	
34	062630612	2	ナベコ238-56X6	SCREW, PAN SM2.38-56X6	
35	S08921101	1	ゼンゴコマクミ	LONGITUDINAL BLOCK ASSY	
35-1	S09251001	1	ゼンゴコマネジツキ	LONGITUDINAL BLOCK WITH SCREW	
35-1-1	120990001	2	アタマツキトメネジ4.37	SET SCREW, SM4.37	
35-2	140313001	1	ゼンゴレバークミ	LONGITUDINAL FEED LEVER SLIDE BLOCK	
37	S11589000	1	ダストシール	DUST SEAL	
			<0D2-0, 012-0>	<0D2-0, 012-0>	
10-1	S08912001	1	ルーハホルダ	LOOPER HOLDER	
12-1	018771432	1	アナボルト635-40X14	BOLT, SOCKET SM6.35-40X14	
14-1	S40569001	1	ルーバ	LOOPER	
15-1	014680422	1	アナトメネジ4.37クボミ	SET SCREW, SOCKET (CP) SM4.37	
			<012-T>	<012-T>	
10-2	S40976001	1	ルーバホルダL	LOOPER HOLDER	
10-3	S40975001	1	ルーバホルダR	LOOPER HOLDER	
12-2	018771432	2	アナボルト635-40X14	BOLT, SOCKET SM6.35-40X14	
13	155162001	2	スヘーサ	SPACER	
14-2	S40973001	1	ルーバL	LOOPER (L)	
14-3	S40974001	1	ルーバR	LOOPER (R)	
15-2	014680422	2	アナトメネジ4.37クボミ	SET SCREW, SOCKET (CP) SM4.37	
			<012-5, 013-□, 014-□, 015-□>	<012-5, 013-□, 014-□, 015-□>	
10-2	S40976001	1	ルーバホルダL	LOOPER HOLDER	
10-3	S40975001	1	ルーバホルダR	LOOPER HOLDER	
12-2	018771432	2	アナボルト635-40X14	BOLT, SOCKET SM6.35-40X14	
13	155162001	2	スヘーサ	SPACER	
14-2	S40973001	1	ルーバL	LOOPER (L)	
14-3	S40974001	1	ルーバR	LOOPER (R)	
15-2	014680422	2	アナトメネジ4.37クボミ	SET SCREW, SOCKET (CP) SM4.37	
16	S40996001	2	カンザ	WASHER	



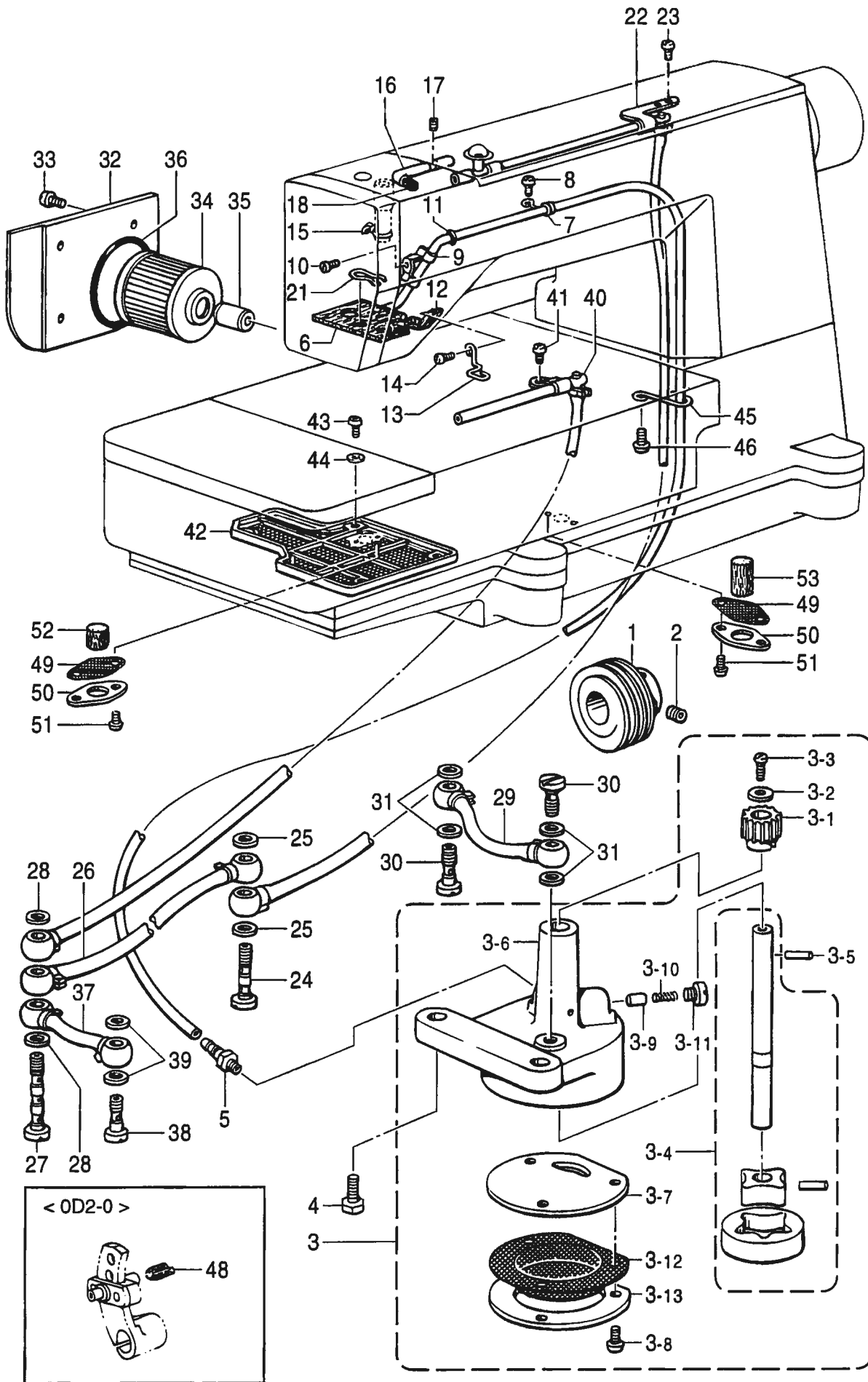

K. 給油潤滑関係 / Lubrication / Schmierung / Lubrification / Lubricación

REF.NO.	CODE	Q'TY	ヒンメイ	NAME OF PARTS	RM
1	S08935001	1	ウオーム	WORM	
2	014770622	2	アナトメネジ6.35クボミ	SET SCREW, SOCKET (CP) SM6.35	
3	S08936201	1	トロコイドポンプクミ	PUMP ASSY	
3-1	144619000	1	ウオームホイール	WORM WHEEL	
3-2	025350332	1	ヒラザガネダイ3.5	WASHER, PLAIN L 3.5	
3-3	062670812	1	ナベコ3.57-40X8	SCREW, PAN SM3.57-40X8	
3-4	S08937101	1	ポンプロータークミ	PUMP INNER ROTER ASSY	
3-5	144622001	1	ミゾツキヒンEガタ	DOWEL PIN (E)	
3-6	S08939100	1	ポンプケース	PUMP CASE	
3-7	147527000	1	ポンプフタ	PUMP COVER	
3-8	062671012	3	ナベコ357-40X10	SCREW, PAN SM3.57-40X10	
3-9	144875001	1	フランジヤー	PLUNGER	
3-10	144876001	1	フランジヤーバネ	SPRING, COMPRESSION	
3-11	112467002	1	シメネジ6.35	SCREW, SM6.35X5	
3-12	147528100	1	ロカモウ	OIL FILTER	
3-13	147529000	1	ロカモウオサエ	OIL FILTER FLANGE	
4	017781412	2	ボルト6.35X14	BOLT, SM6.35X14	
5	142359001	1	オイルクチ	OIL FEEDING PIPE	
6	S08940000	1	チューブクミ	OIL TUBE ASSY	
7	112743001	1	クミヒモササエ	WICK SUPPORT	
8	062670612	1	ナベコ357-40X6	SCREW, PAN SM3.57-40X6	
9	151429001	1	チューブホルダ	TUBE HOLDER	
10	062670612	1	ナベコ357-40X6	SCREW, PAN SM3.57-40X6	
11	118770001	1	ハツキン	PACKING	
12	S08943000	1	カクゴマフェルト	FELT	
13	S08944001	1	フェルトオサエ	FELT SUPPORT	
14	062670612	1	ナベコ357-40X6	SCREW, PAN SM3.57-40X6	
15	157840000	1	クミヒモ3X3	WICK, 3X3 L = 100	
16	S08945001	1	オイルパイプ	OIL PIPE	
17	014680622	1	アナトメネジ4.37クボミ	SET SCREW, SOCKET (CP) SM4.37	
18	S08946000	1	フェルト	FELT	
21	145737001	1	フェルトオサエ	FELT SUPPORT	
22	S08948001	1	ロッドオイルパイプクミ	MAIN OIL PIPE (U) ASSY	
23	062670612	2	ナベコ357-40X6	SCREW, PAN SM3.57-40X6	
24	112364001	1	ハイユハイブツギテネジ	OIL FEEDING PIPE JOINT SCREW	
25	159476000	2	ザガネ	WASHER	
26	S08951001	1	ビニルチューブクミ	OIL TUBE ASSY	
27	112351001	1	ハイユハイブネジ	OIL FEEDING PIPE SCREW	
28	159476000	2	ザガネ	WASHER	
29	155282101	1	ビニルチューブクミ	OIL TUBE ASSY	
30	112359052	2	ハイユハイブツギテネジ	SCREW	
31	159476000	4	ザガネ	WASHER	
32	S08955051	1	オイルフィルターフタ	OIL FILTER CAP	
33	062680812	4	ナベコ437-40X8	SCREW, PAN SM4.37-40X8	
34	S08956100	1	オイルフィルター	OIL FILTER	
35	S08957001	1	オイルクチ	OIL FEEDING PIPE	
36	081044070	1	OリングP44	O RING, P44	
37	S08953001	1	ビニルチューブクミ	OIL TUBE ASSMBLY	
38	112359052	1	ハイユハイブツギテネジ	SCREW	
39	159476000	2	ザガネ	WASHER	
40	S08958001	1	ロッドオイルパイプDクミ	MAIN OIL PIPE (D) ASSY	
41	062670612	1	ナベコ357-40X6	SCREW, PAN SM3.57-40X6	
42	S09316000	1	オイルフィルターD	OIL FILTE (D)	
43	062680812	4	ナベコ437-40X8	SCREW, PAN SM4.37-40X8	
44	100645003	4	ザガネ	WASHER	
45	S09125001	1	チューブガイド	OIL TUBE GUIDE	
46	062780812	1	ナベコ635-28X8	SCREW, PAN SM6.35-28X8	
49	155294100	2	ロカモウ	OIL FILTER	
50	155295001	2	ロカモウオサエイタ	OIL FILTER FLANGE	
51	062670612	4	ナベコ357-40X6	SCREW, PAN SM3.57-40X6	
52	151927001	1	クラツチフェルト	FELT, CLUTCH	
53	112754001	1	フェルト	FELT	
-----					
48	147363000	1	<0D2-0> フェルト	<0D2-0> FELT	



## L. 糸調子関係 / Thread tension / Faderspannung / Tension du fil / Tensión del hilo

REF.NO.	CODE	Q'TY	ヒンメイ	NAME OF PARTS	RM
1	S08961101	1	シユイトアンナイ	MAIN THREAD GUIDE	
2	062680812	2	ナベコ437-40X8	SCREW, PAN SM4.37-40X8	
4	150645009	2	イトアンナイパイPL	THREAD GUIDE PIPE, L	
6	014680422	1	アナトメネジ4.37クホミ	SET SCREW, SOCKET (CP) SM4.37	
7	S08962109	1	イトチヨウシダイ	TENSION BRACKET	
8	062681012	2	ナベコ437-40X10	SCREW, PAN SM4.37-40X10	
27	S08965009	1	イトユルメイタ	TENSION RELEASE PLATE	
28	S08966001	1	イトユルメジク	TENSION RELEASE SHAFT	
29	S08967001	2	シメネジ4.76	SCREW, SM4.76	
30	118718001	1	オサエボウダキオシバネ	SPRING, COMPRESSION	
31	S08968001	1	イトユルメウデ	TENSION RELEASE ARM	
32	062681212	1	ナベコ437-40X12	SCREW, PAN SM4.37-40X12	
39	100645003	1	ザガネ	WASHER	
40	S08969201	1	チユウカンイトアンナイ	THREAD GUIDE	
41	018680822	1	アナボルト4.37X8	BOLT, SOCKET SM4.37X8	
42	143602001	1	ミゾツキピン	DOWEL PIN	
45	S08971201	1	ハリイトクリヘンシンリンクミ	NEEDLE THREAD TAKE-UP ECCENTRIC ASSY	
45-1	014770622	2	アナトメネジ6.35クホミ	SET SCREW, SOCKET (CP) SM6.35	
45-2	018401422	2	アナボルト4X14	BOLT, SOCKET M4X14	
47	018771432	1	アナボルト635-40X14	BOLT, SOCKET SM6.35-40X14	
48	155220000	1	ホジヨアツメタルR	AUTO PRESSER ARM BUSH (R)	
49	S08770000	1	ジクメタル	SHAFT BUSH	
50	S08976001	1	ハリイトクリジク	NEEDLE THREAD TAKE-UP SHAFT	
51	S00356001	1	ザガネ	WASHER	
52	S00383001	1	ボルト5.56X8	BOLT, M5.56X8	
53	155539000	1	ダストシール	DUST SEAL	
54	S08977001	1	ハリイトクリレバー	NEEDLE THREAD TAKE-UP LEVER	
55	018771432	1	アナボルト635-40X14	BOLT, SOCKET SM6.35-40X14	
56	155162001	1	スヘーサ	SPACER	
57	S08978001	1	ハリイトクリ	NEEDLE THREAD TAKE-UP	
58	062681012	2	ナベコ437-40X10	SCREW, PAN SM4.37-40X10	
59	100645003	2	ザガネ	WASHER	
68	S08981001	1	ハリボウテンピン	NEEDLE BAR TAKE-UP	
69	062670612	1	ナベコ357-40X6	SCREW, PAN SM3.57-40X6	
71	014680422	1	アナトメネジ4.37クホミ	SET SCREW, SOCKET (CP) SM4.37	
72	S08983001	1	アームハリイトウケ	ARM NEEDLE THREAD GUIDE	
73-1	S28438001	1	アームイトアンナイD	ARM THREAD GUIDE (D)	
74	062680812	1	ナベコ437-40X8	SCREW, PAN SM4.37-40X8	
92	062680612	1	ナベコ4.37-40X6	SCREW, PAN SM4.37-40X6	
94	S18530001	1	テンビンダイDクミ	LOOPER THREAD TAKE-UP BASE (D) ASSY	
95	060680712	2	バインド437-40X7	SCREW, BIND SM4.37-40X7	
96	S18532001	1	テンビンダイUクミ	LOOPER THREAD TAKE-UP BASE (U) ASSY	
96-1	146924000	1	スレツドブツシュ	THREAD BUSH	
97	018680822	2	アナボルト4.37X8	BOLT, SOCKET SM4.37X8	
98	S18534001	1	ドダイオサエバネ	SPRING	
99	062670512	1	ナベコ357-40X5	SCREW, PAN SM3.57-40X5	
100	S18535001	1	イトオサエドダイ	THREAD PRESSER BASE	
101	154965001	1	アナボルト3.57X8	BOLT, SOCKET SM3.57X8	
102	S08992001	1	テンビンイトオサエ	LOOPER TAKE-UP PRESSER	
103	154965001	1	アナボルト3.57X8	BOLT, SOCKET SM3.57X8	
104	S08987001	1	イトチヨウシボウ	THREAD TENSION CONTROL STUD	
105	144504001	2	イトアンナイサラ	DISC, THREAD GUIDE	
106	144505000	1	イトアンナイバネ	SPRING	
107	155510001	1	イトチヨウシナツト	TENSION NUT	
108	S08993101	1	テンビンイトウケ	TAKE-UP THREAD GUIDE	
109	062670512	1	ナベコ357-40X5	SCREW, PAN SM3.57-40X5	
110	105161004	1	ザガネ	WASHER	
111	S08994001	2	テンビンイトアンナイ	THREAD GUIDE	
112	060660416	2	バインド318-40X4	SCREW, BIND SM3.18-40X4	
114	144075001	1	ボルト3.57	BOLT, SM3.57	
115	105161004	1	ザガネ	WASHER	
116	S40572001	1	シタイトテンピンクミ	LOOPER THREAD TAKE-UP ASSY	
117	014680422	2	アナトメネジ4.37クホミ	SET SCREW, SOCKET (CP) SM4.37	
120	S40570001	1	イトアンナイDダイ	THREAD GUIDE BRACKET	
121	060670812	2	バインド357-40X8	SCREW, BIND SM3.57-40X8	
126	062670512	1	ナベコ357-40X5	SCREW, PAN SM3.57-40X5	
127	105161004	1	ザガネ	WASHER	
128	S12882001	1	イトアンナイ	THREAD GUIDE	
129	S25818051	1	チヨウセツレバーストツバ	STOPPER, ADJUSTING LEVER	
130	062350612	1	ナベコM3.5X6	SCREW, PAN M3.5X6	

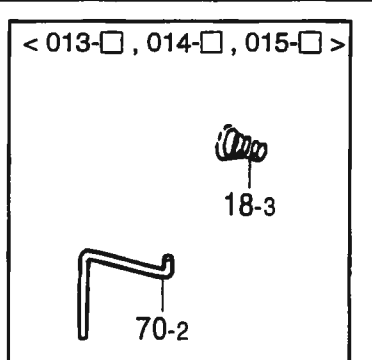
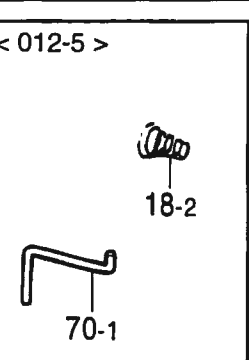
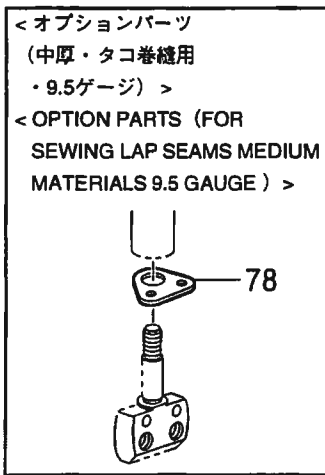
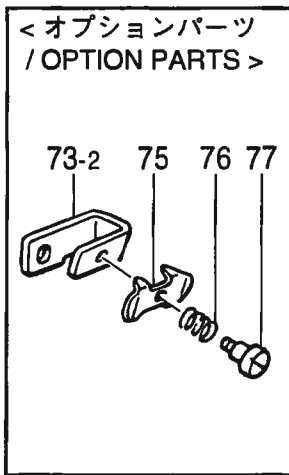
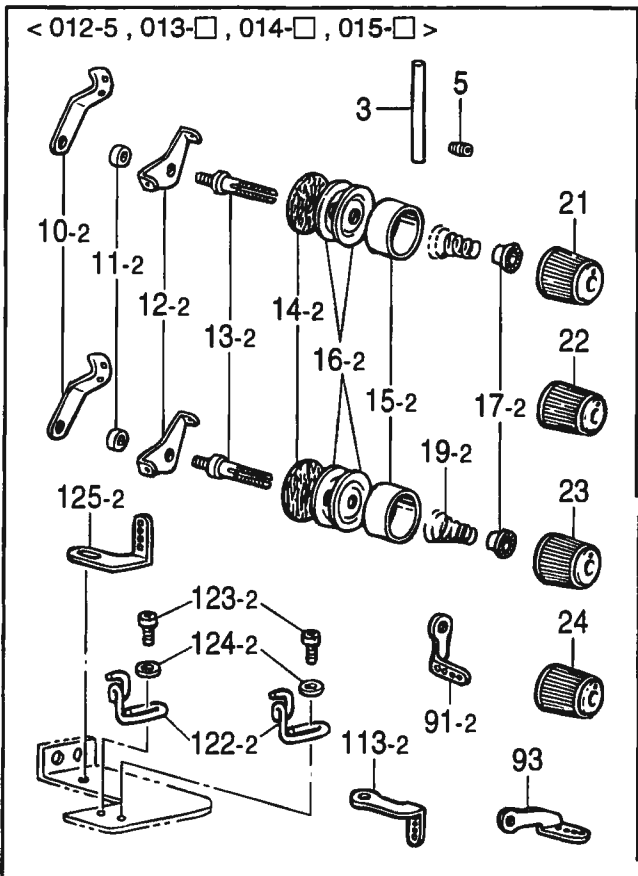
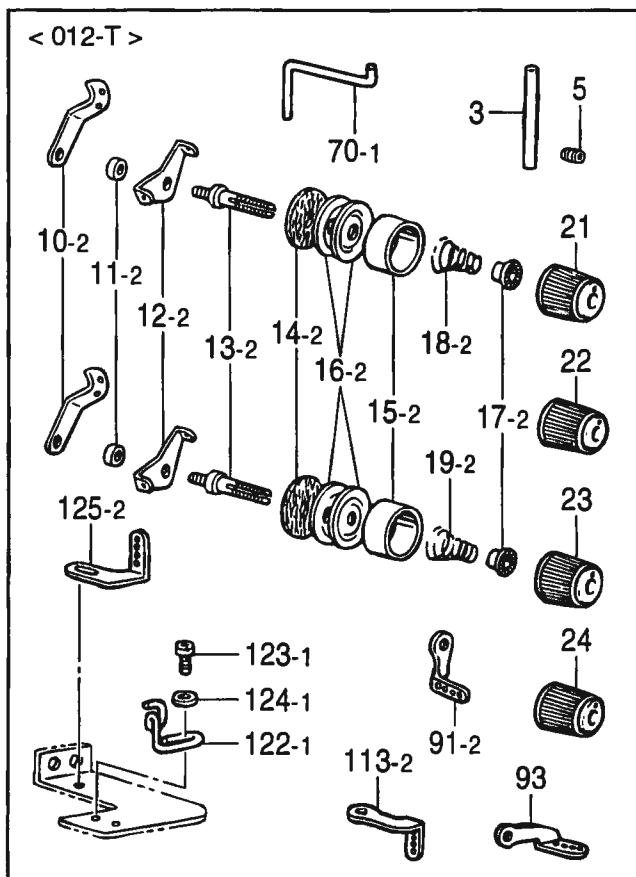
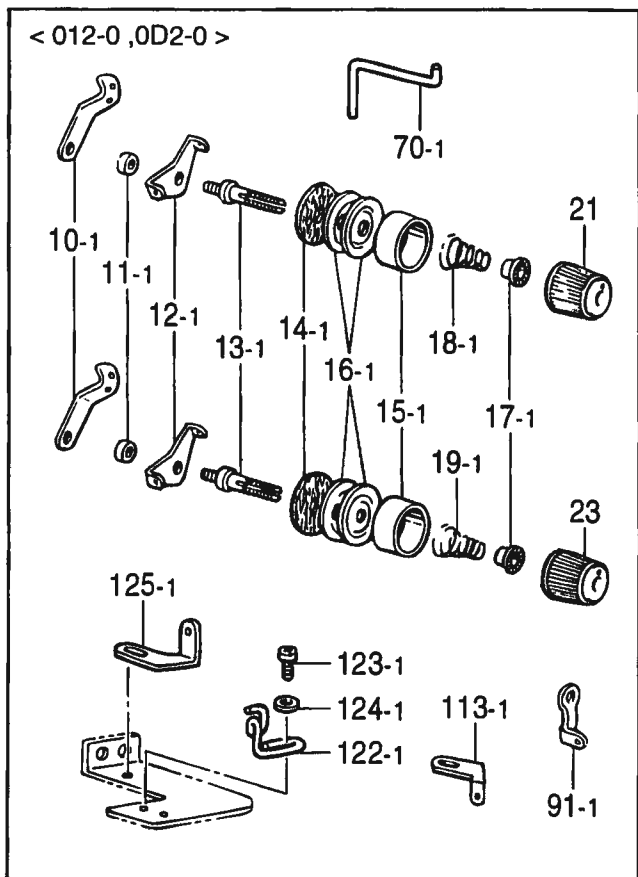

L. 糸調子関係 / Thread tension / Faderspannung / Tension du fil / Tensión del hilo

REF.NO.	CODE	Q'TY	ヒンメイ	NAME OF PARTS	RM
			<0D2-0, 012-0>	<0D2-0, 012-0>	
10-1	S08963001	2	イトチヨウシダイイトアンナイ	TENSION BRACKET THREAD GUIDE	
11-1	S08964001	2	カンザ	SPACER	
12-1	110813001	2	ハリイトアンナイ	NEEDLE THREAD GUIDE	
13-1	159574101	2	イトチヨウシボウ	TENSION STUD	
14-1	110832009	2	イトチヨウシサラフェルト	TENSION DISC FELT	
15-1	144103009	2	イトチヨウシサラオサエ	TENSION DISC PRESSER	
16-1	145446001	4	イトチヨウシサラ	DISC, TENSION	
17-1	S30564000	2	チヨウシバネウエザガネ	TENSION SPRING WASHER	
18-1	144104001	1	ハリイトチヨウシバネ	THREAD TENSION ADJUST SPRING	
19-1	144110001	1	シタルーパイトチヨウシバネ	THREAD TENSION ADJUST SPRING	
21	S30565003	1	イトチヨウシナツト	TENSION NUT, RED	
23	S30565003	1	イトチヨウシナツト	TENSION NUT, RED	
70-1	S08982001	1	ハリイトウケ	NEEDLE THREAD GUIDE	
91-1	S08970001	1	イトアンナイS	THREAD GUIDE, S	
113-1	155313001	1	ウフルーハイトアンナイ	LOOPER THREAD GUIDE	
122-1	S40571001	1	シタイトアンナイF	LOWER THREAD GUIDE (F)	
123-1	062670612	1	ナベコ357-40X6	SCREW, PAN SM3.57-40X6	
124-1	105161004	1	ザガネ	WASHER	
125-1	155313001	1	ウフルーハイトアンナイ	LOOPER THREAD GUIDE	
			<012-5, 013-□, 014-□, 015-□>	<012-5, 013-□, 014-□, 015-□>	
3	150644009	1	イトアンナイパイプS	THREAD GUIDE PIPE (S)	
5	014680422	1	アナトメネジ4.37クボミ	SET SCREW, SOCKET (CP) SM4.37	
10-2	S08963001	4	イトチヨウシダイイトアンナイ	TENSION BRACKET THREAD GUIDE	
11-2	S08964001	4	カンザ	SPACER	
12-2	110813001	4	ハリイトアンナイ	NEEDLE THREAD GUIDE	
13-2	159574101	4	イトチヨウシボウ	TENSION STUD	
14-2	110832009	4	イトチヨウシサラフェルト	TENSION DISC FELT	
15-2	144103009	4	イトチヨウシサラオサエ	TENSION DISC PRESSER	
16-2	145446001	8	イトチヨウシサラ	DISC, TENSION	
17-2	S30564000	4	チヨウシバネウエザガネ	TENSION SPRING WASHER	
19-2	144110001	2	シタルーパイトチヨウシバネ	THREAD TENSION ADJUST SPRING	
21	S30565003	1	イトチヨウシナツト	TENSION NUT, RED	
22	S30565002	1	イトチヨウシナツト	TENSION NUT, GREEN	
23	S30565003	1	イトチヨウシナツト	TENSION NUT, RED	
24	S30565002	1	イトチヨウシナツト	TENSION NUT, GREEN	
91-2	S12882001	1	イトアンナイ	THREAD GUIDE	
93	S12882001	1	イトアンナイ	THREAD GUIDE	
113-2	S12882001	1	イトアンナイ	THREAD GUIDE	
122-2	S40571001	2	シタイトアンナイF	LOWER THREAD GUIDE (F)	
123-2	062670612	2	ナベコ357-40X6	SCREW, PAN SM3.57-40X6	
124-2	105161004	2	ザガネ	WASHER	
125-2	S12882001	1	イトアンナイ	THREAD GUIDE	
			<012-5>	<012-5>	
18-2	144104001	2	ハリイトチヨウシバネ	THREAD TENSION ADJUST SPRING	
70-1	S08982001	1	ハリイトウケ	NEEDLE THREAD GUIDE	
			<013-□, 014-□, 015-□>	<013-□, 014-□, 015-□>	
18-3	148851001	2	ハリイトチヨウシバネ	TENSION SPRING	
70-2	S44911001	1	ハリイトウケ	NEEDLE THREAD GUIDE	
			<012-T>	<012-T>	
3	150644009	1	イトアンナイパイプS	THREAD GUIDE PIPE (S)	
5	014680422	1	アナトメネジ4.37クボミ	SET SCREW, SOCKET (CP) SM4.37	
10-2	S08963001	4	イトチヨウシダイイトアンナイ	TENSION BRACKET THREAD GUIDE	
11-2	S08964001	4	カンザ	SPACER	
12-2	110813001	4	ハリイトアンナイ	NEEDLE THREAD GUIDE	
13-2	159574101	4	イトチヨウシボウ	TENSION STUD	
14-2	110832009	4	イトチヨウシサラフェルト	TENSION DISC FELT	

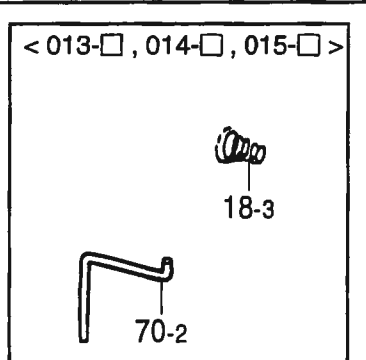
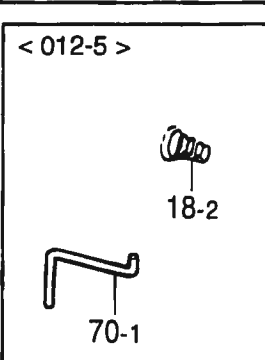
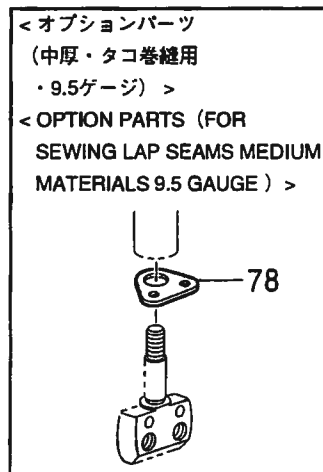
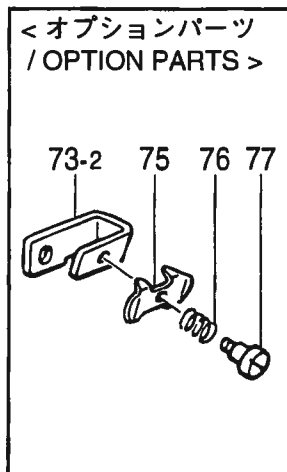
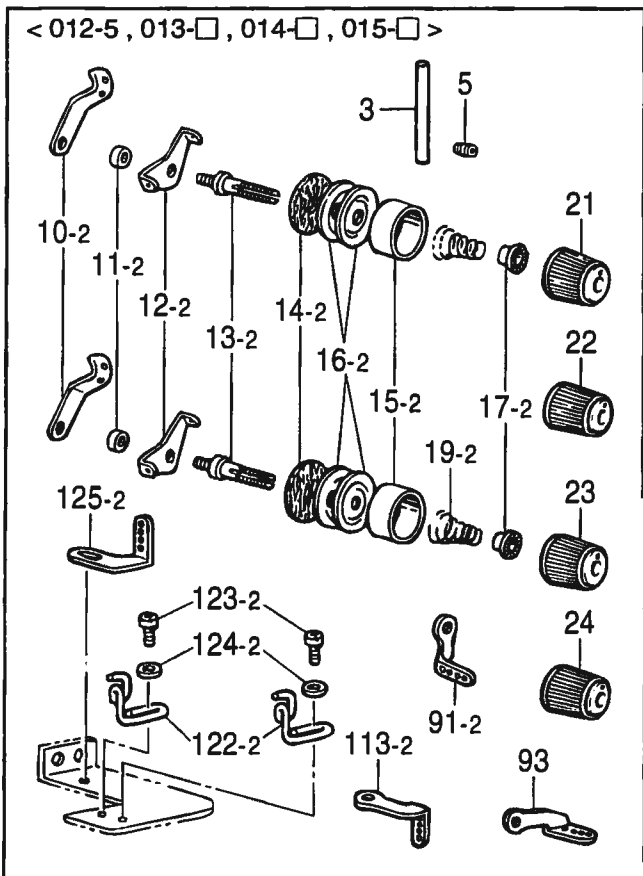
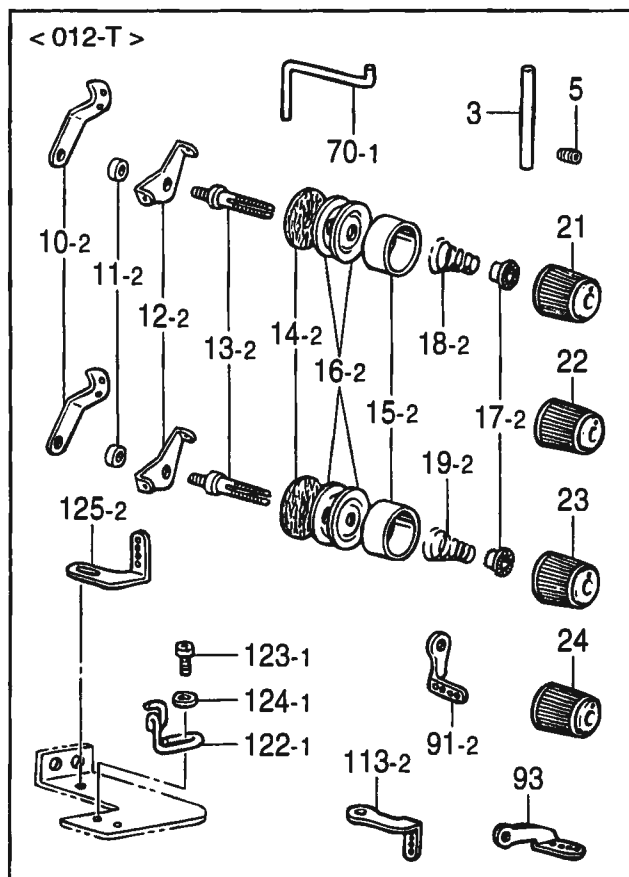
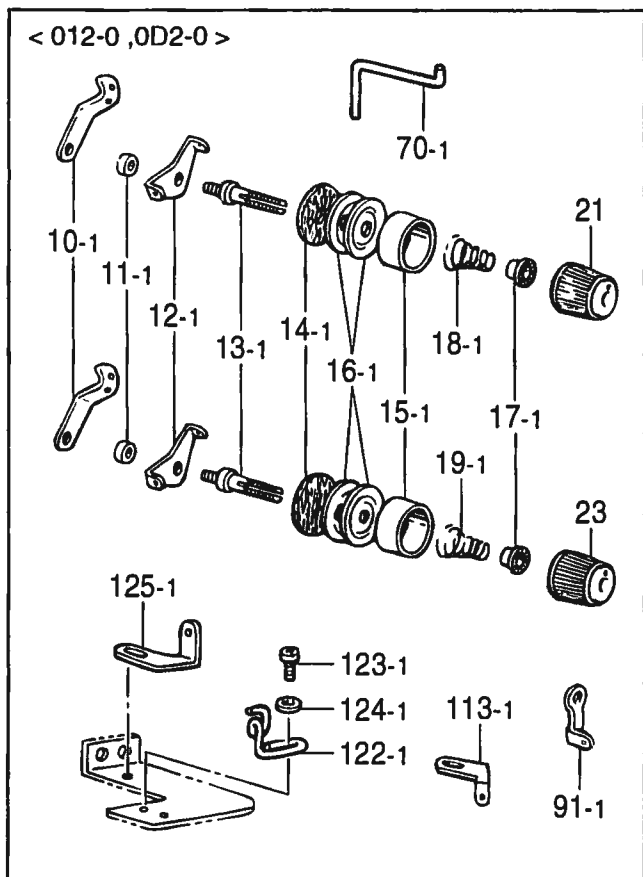

L. 糸調子関係 / Thread tension / Faderspannung / Tension du fil / Tensión del hilo

REF.NO.	CODE	Q'TY	ヒンメイ	NAME OF PARTS	RM
15-2	144103009	4	イトチヨウシサラオサエ	TENSION DISC PRESSER	
16-2	145446001	8	イトチヨウシサラ	DISC, TENSION	
17-2	S30564000	4	チヨウシバネウエザガネ	TENSION SPRING WASHER	
18-2	144104001	2	ハリイトチヨウシバネ	THREAD TENSION ADJUST SPRING	
19-2	144110001	2	シタルーハイトチヨウシバネ	THREAD TENSION ADJUST SPRING	
21	S30565003	1	イトチヨウシナツト	TENSION NUT, RED	
22	S30565002	1	イトチヨウシナツト	TENSION NUT, GREEN	
23	S30565003	1	イトチヨウシナツト	TENSION NUT, RED	
24	S30565002	1	イトチヨウシナツト	TENSION NUT, GREEN	
70-1	S08982001	1	ハリイトウケ	NEEDLE THREAD GUIDE	
91-2	S12882001	1	イトアンナイ	THREAD GUIDE	
93	S12882001	1	イトアンナイ	THREAD GUIDE	
113-2	S12882001	1	イトアンナイ	THREAD GUIDE	
122-1	S40571001	1	シタイトアンナイF	LOWER THREAD GUIDE (F)	
123-1	062670612	1	ナベコ357-40X6	SCREW, PAN SM3.57-40X6	
124-1	105161004	1	ザガネ	WASHER	
125-2	S12882001	1	イトアンナイ	THREAD GUIDE	
			<オプションパーツ>	<OPTION PARTS>	
73-2	S08984001	1	サブテンシヨンドダイ	SUB TENSION BASE	
75	112300001	1	ハリイトオサエ	NEEDLE THREAD CLAMP	
76	112299001	1	ハリイトアンナイオシバネ	COIL SPRING	
77	112301001	1	ダンネジ3.18	SHOULDER SCREW, M3.18	
			<オプションパーツ (中厚タコ巻縫用9.5ゲージ)>	<OPTION PARTS(FOR SEWING LAP SEAMS MEDIUM MATERIALS 9.5GAUGE)>	
78	115904001	1	ハリボウイトアンナイ	THREAD GUIDE, NEEDLE BAR	



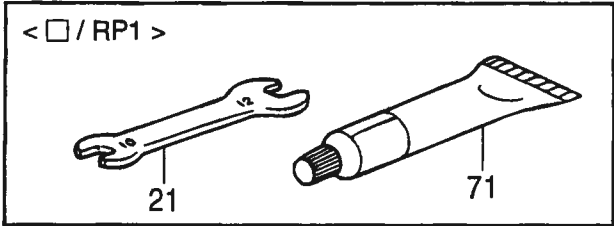
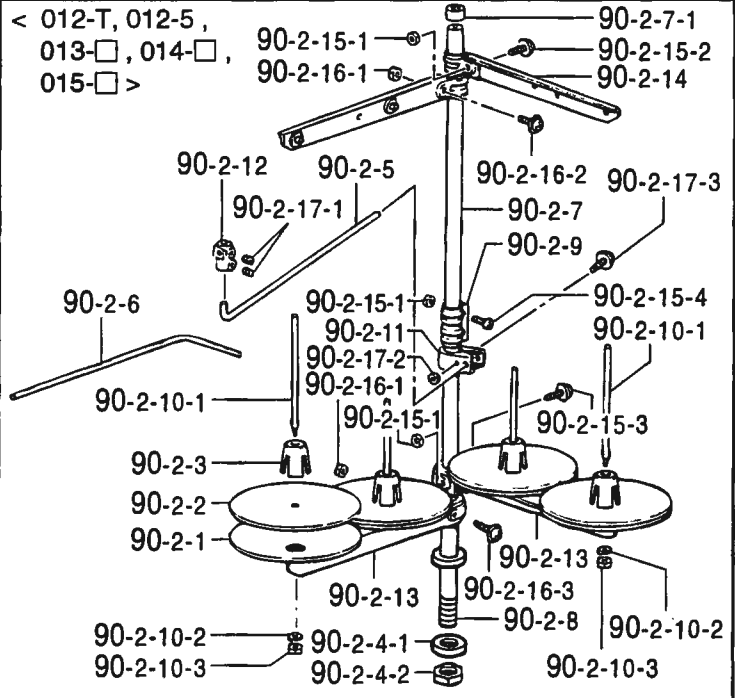
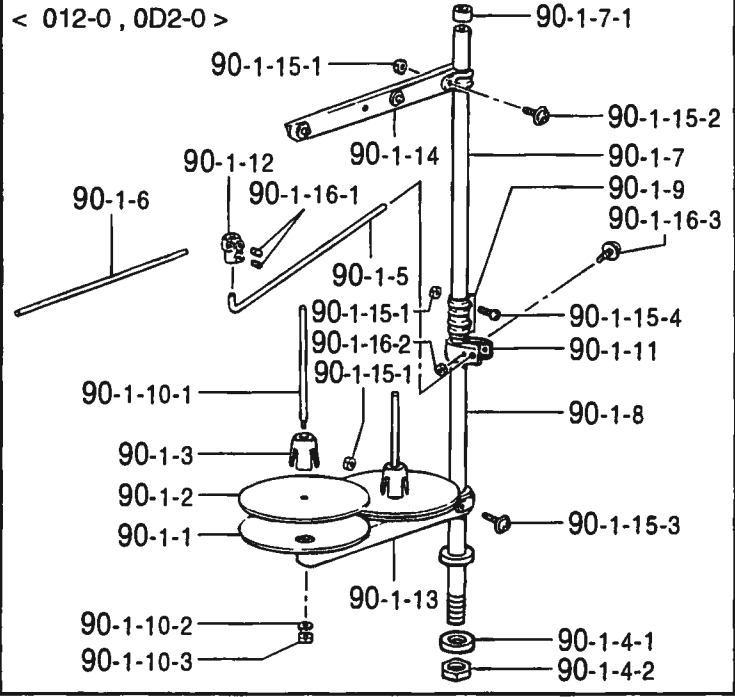
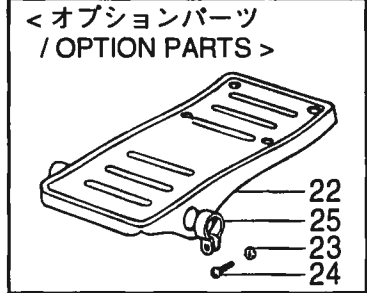
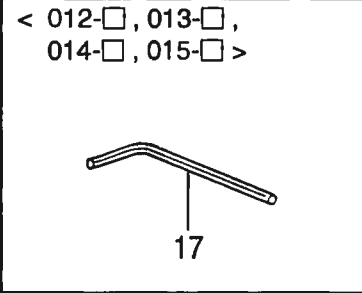
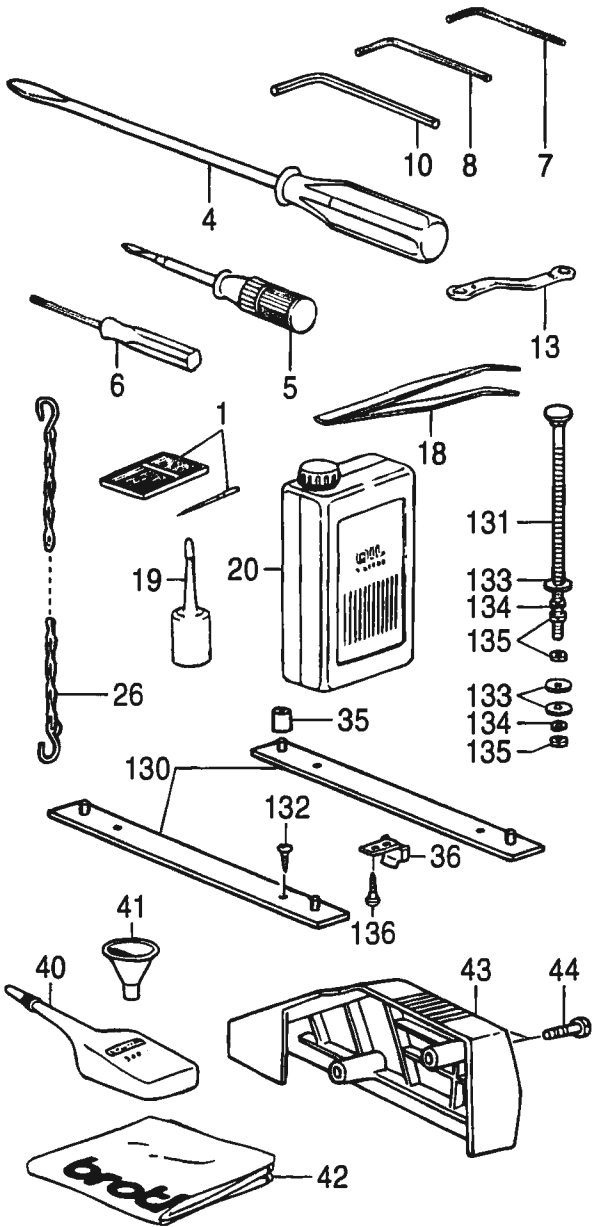

- ◎ 付属品の明細は変更することがあります。
- ◎ The details of included accessories are subject to change.
- ◎ Änderungen in der Aufstellung der Mitgelieferten Zubehöre sind vorbehalten.
- ◎ Les détails des accessoires inclus sont sujets à des changements.
- ◎ Los detalles de los accesorios incluidos pueden variar.

## Z. 付属品関係 / Accessories / Zubehör / Accessoires / Accesorios

REF.NO.	CODE	Q'TY	ヒンメイ	NAME OF PARTS	RM
4	101572101	1	ネジマワシ5.5X190	SCREW DRIVER, 5.5X190	
5	118837001	1	ネジマワシ3.4X70	SCREW DRIVER, 3.4X70	
6	S01943001	1	6カクボウネジマワシ1.6	SCREW DRIVER, HEX. 1.6	
7	146049001	1	6カクボウスパナ2	HEXAGONAL WRENCH, 2	
8	142721001	1	6カクボウスパナ3	HEXAGONAL WRENCH, 3	
10	150335001	1	6カクボウスパナ5	HEXAGONAL WRENCH, 5	
13	105343001	1	メガネレンチ8X9	WRENCH, 8X9	
18	117466000	1	ピンセット	PINCETTE	
19	S06701000	1	ポリオイラークミ	POLY OILER ASSY	
20	145277205	1	オイルタンク	OIL TANK	
26	149247001	1	クサリクミ	CHAIN ASSY	
35	147919051	4	ボウシンゴム	RUBBER CUSHION	
36	S09001101	1	クサリガイド	CHAIN GUIDE	
40	S06704001	1	シリコンオイル	SILICONE OIL	
41	140759000	1	ジヨーゴ	FUNNEL	
42	144224001	1	トウブカバー	HEAD COVER	
43	S09002009	1	ベルトカバー	BELT COVER	
44	102424004	2	シメネジ4.37	SCREW, M4.37	
130	S11561001	2	トウブウケイタ	HEAD SPOOL PLATE	
131	S11562001	4	カクネマルアタマボルト	BOLT	
132	100666002	4	マルモクネジ5.5X20	WOOD SCREW, ROUND M5.5X20	
133	025080336	12	ヒラザガネダイ8	WASHER, PLAIN L 8	
134	028080242	8	バネザガネ2-8	WASHER, SPRING 2-8	
135	021080106	12	ナツト1シユ8	NUT, 1 M8	
136	032461606	2	+マルモクネジ4.5X16	WOOD SCREW, ROUND M4.5X16	
			<0D2-0, 012-0>	<0D2-0, 012-0>	
90-1	S40574009	1	イトタテダイクミ2DTHF	COTTON STAND ASSY, 2DTHF	
90-1-1	150180001	2	ウケザラ	SPOOL STAND BASE	
90-1-2	150182000	2	スプールマット	SPOOL MAT	
90-1-3	126863001	2	スプールクツシヨン	SPOOL CUSHION	
90-1-4	S02775001	1	ハイブネジセットA	PIPE SCREW SET, A	
90-1-4-1	150206002	1	ヒラザガネ16	WASHER, PLAIN 16	
90-1-4-2	S38648001	1	6カクナツトU5/8	NUT, U5/8-28	
90-1-5	S04109001	1	イトアンナイササエホウ	THREAD GUIDE SUPPORT BAR	
90-1-6	142997001	1	イトアンナイ3	THREAD GUIDE, 3	
90-1-7	S40640001	1	コラムパイプキャツフツキ	COLUMN PIPE W/CAP	
90-1-7-1	150174000	1	コラムキャツフ	COLUMN CAP	
90-1-8	156112003	1	コラムハイブD	COLUMN PIPE, D	
90-1-9	150173003	1	コラムジョイント	COLUMN JOINT	
90-1-10	S21798001	2	スプールネジセット	SPOOL SCREW SET	
90-1-10-1	150179002	2	スプールジクB	SPOOL SHAFT, B	
90-1-10-2	028050246	2	バネザガネ2-5	WASHER, SPRING 2-5	
90-1-10-3	021500106	2	1シユナツト5	NUT, 1 M5	
90-1-11	150185009	1	イトアンナイホルダー	THREAD GUIDE HOLDER	
90-1-12	138843001	1	ササエボウツギテ	JOINT	
90-1-13	S02778002	1	スプールホルダー2	SPOOL HOLDER, 2	
90-1-14	S02786002	1	スレツドハンガークミ2	THREAD HANGER ASSY, 2	
90-1-15	S40641001	1	スプールジクネジセットA	SPOOL SCREW SET, A	
90-1-15-1	021500106	4	1シユナツト5	NUT, 1 M5	
90-1-15-2	S37038001	1	ナベコヒラザ5X14	SCREW, PAN (S/P WASHER) M5X14	
90-1-15-3	S37037001	1	ナベコヒラザ5X32	SCREW, PAN (S/P WASHER) M5X32	
90-1-15-4	062501406	2	ナベコ5X14	SCREW, PAN M5X14	
90-1-16	S40643001	1	ホルダーツギテネジセット	HOLDER JOINT SCREW SET	
90-1-16-1	014060632	2	アナトメ6X6クボミ	SET SCREW, SOCKET (CP) M6X6	
90-1-16-2	021500106	1	1シユナツト5	NUT, 1 M5	
90-1-16-3	S37037001	1	ナベコヒラザ5X32	SCREW, PAN (S/P WASHER) M5X32	

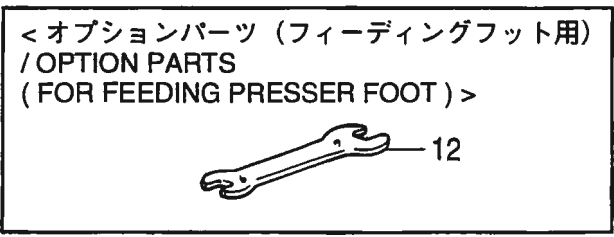
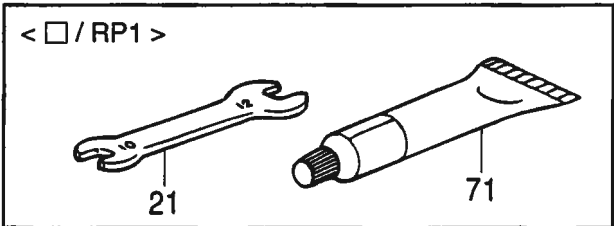
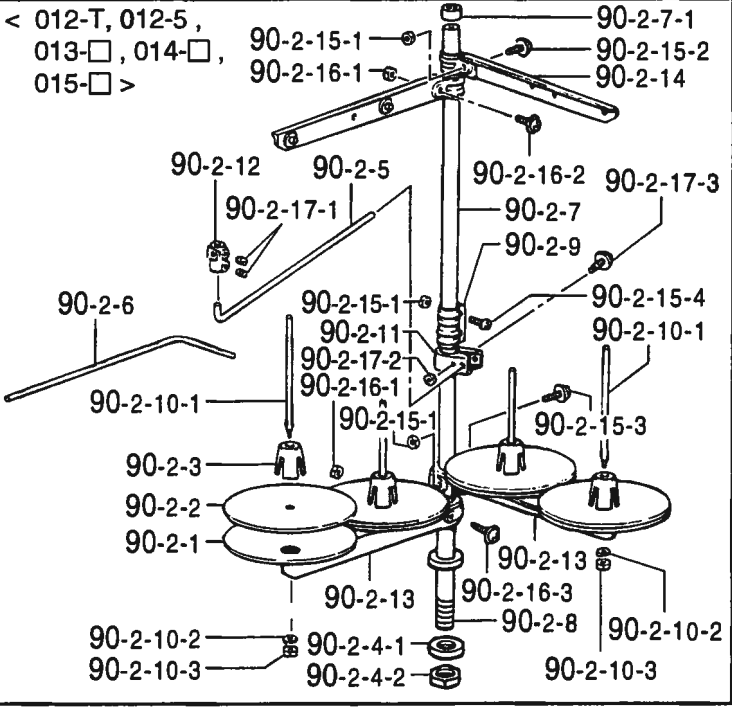
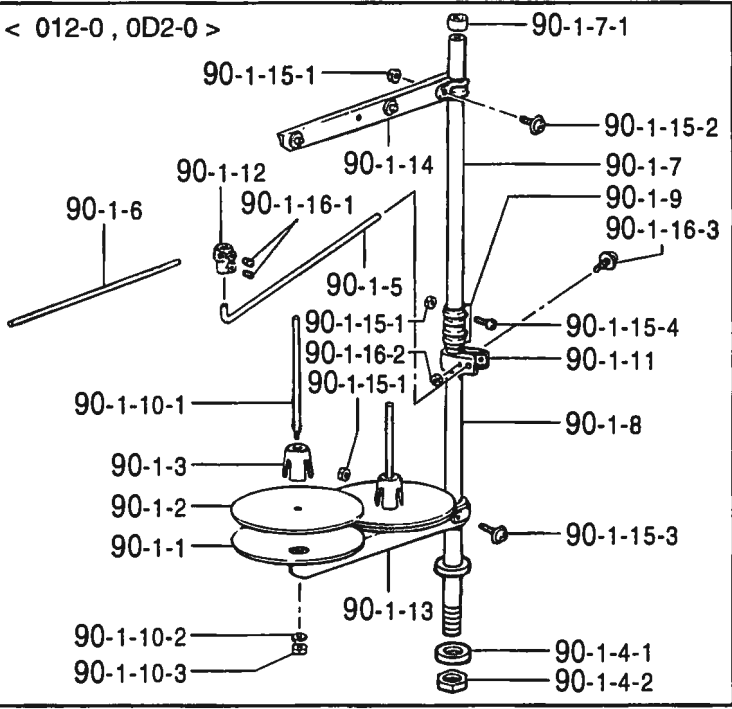
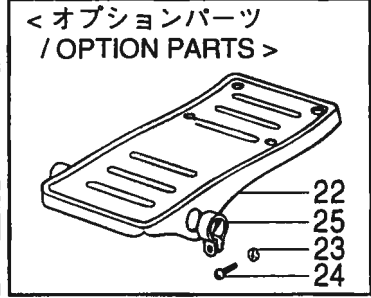
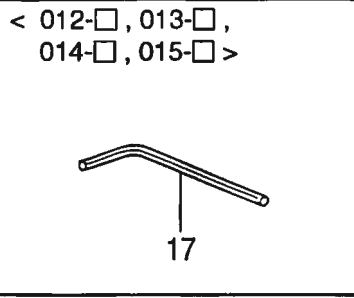
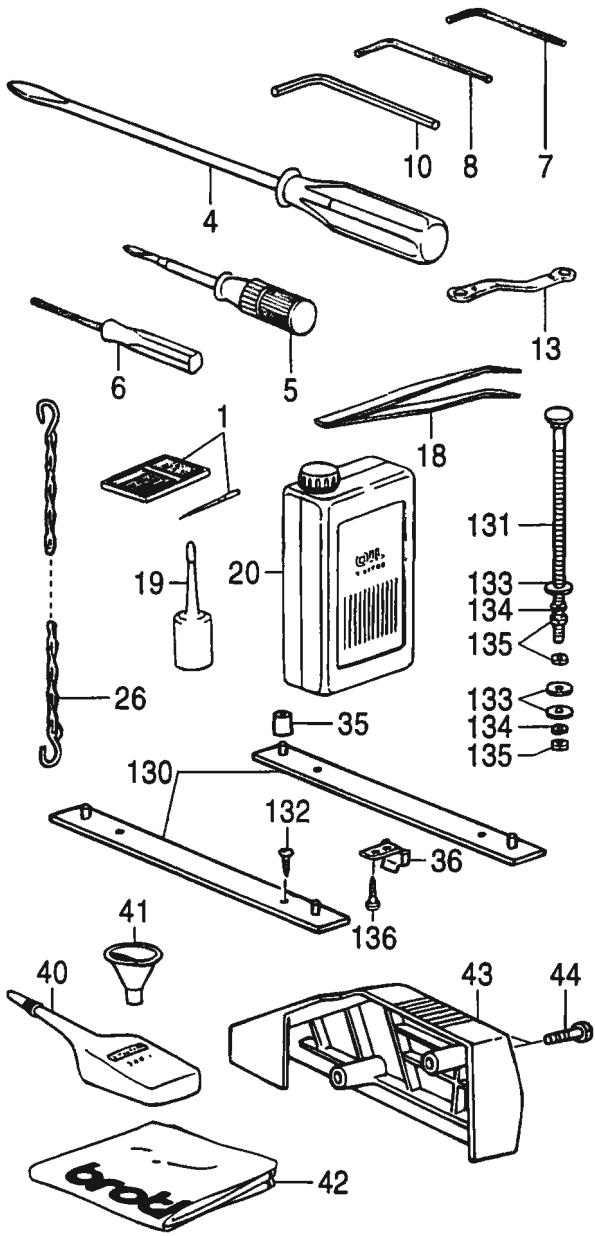

- ◎ 付属品の明細は変更することがあります。
- ◎ The details of included accessories are subject to change.
- ◎ Änderungen in der Aufstellung der Mitgelieferten Zubehöre sind vorbehalten.
- ◎ Les détails des accessoires inclus sont sujets à des changements.
- ◎ Los detalles de los accesorios incluidos pueden variar.











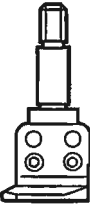
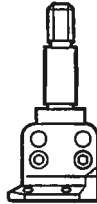





Z. 付属品関係 / Accessories / Zubehör / Accessoires / Accesorios

REF.NO.	CODE	Q'TY	ヒンメイ	NAME OF PARTS	RM
			<012-T, 012-5, 013-□, 014-□, □/RP1>	<012-T, 012-5, 013-□, 014-□, □/RP1>	
90-2	S29854109	1	イトタテダイクミ4DTHF	COTTON STAND ASSY, 4DTHF	
90-2-1	150180001	4	ウケザラ	SPOOL STAND BASE	
90-2-2	150182000	4	スプールマット	SPOOL MAT	
90-2-3	126863001	4	スプールクッション	SPOOL CUSHION	
90-2-4	S02775001	1	ハイブネジセットA	PIPE SCREW SET, A	
90-2-4-1	150206002	1	ヒラザガネ16	WASHER, PLAIN 16	
90-2-4-2	S38648001	1	6カクナツU5/8	NUT, U5/8-28	
90-2-5	S04109001	1	イトアンナイササエボウ	THREAD GUIDE SUPPORT BAR	
90-2-6	142998101	1	イトアンナイ4	THREAD GUIDE, 4	
90-2-7	S40640001	1	コラムハイフキヤツフツキ	COLUMN PIPE W/CAP	
90-2-7-1	150174000	1	コラムキヤツブ	COLUMN CAP	
90-2-8	156112003	1	コラムパイフD	COLUMN PIPE, D	
90-2-9	150173003	1	コラムジョイント	COLUMN JOINT	
90-2-10	S21798001	4	スプールネジセット	SPOOL SCREW SET	
90-2-10-1	150179002	4	スプールジクB	SPOOL SHAFT, B	
90-2-10-2	028050246	4	バネザガネ2-5	WASHER, SPRING 2-5	
90-2-10-3	021500106	4	1シユナツト5	NUT, 1 M5	
90-2-11	150185009	1	イトアンナイホルダー	THREAD GUIDE HOLDER	
90-2-12	138843001	1	ササエボウツギテ	JOINT	
90-2-13	S02778002	2	スプールホルダー2	SPOOL HOLDER, 2	
90-2-14	S02786002	2	スレツドハンガークミ2	THREAD HANGER ASSY, 2	
90-2-15	S40641001	1	スプールジクネジセットA	SPOOL SCREW SET, A	
90-2-15-1	021500106	4	1シユナツト5	NUT, 1 M5	
90-2-15-2	S37038001	1	ナベコヒラザ5X14	SCREW, PAN (S/P WASHER) M5X14	
90-2-15-3	S37037001	1	ナベコヒラザ5X32	SCREW, PAN (S/P WASHER) M5X32	
90-2-15-4	062501406	2	ナベコ5X14	SCREW, PAN M5X14	
90-2-16	S40642001	1	スプールジクネジセットB	SPOOL SHAFT SCREW SET, B	
90-2-16-1	021500106	2	1シユナツト5	NUT, 1 M5	
90-2-16-2	S37038001	1	ナベコヒラザ5X14	SCREW, PAN (S/P WASHER) M5X14	
90-2-16-3	S37037001	1	ナベコヒラザ5X32	SCREW, PAN (S/P WASHER) M5X32	
90-2-17	S40643001	1	ホルダーツギテネジセット	HOLDER JOINT SCREW SET	
90-2-17-1	014060632	2	アナトメ6X6クボミ	SET SCREW, SOCKET (CP) M6X6	
90-2-17-2	021500106	1	1シユナツト5	NUT, 1 M5	
90-2-17-3	S37037001	1	ナベコヒラザ5X32	SCREW, PAN (S/P WASHER) M5X32	
1	S08715116	1	<0D2-0, 012-□> ミシンハリ100クミ	<0D2-0, 012-□> NEEDLE ASSY, #100	
1	S08715121	1	<013-□, 015-□> ミシンハリ130クミ	<013-□, 015-□> NEEDLE, 130 ASSY	
1	S08715122	1	<014-□> ミシンハリ140クミ	<014-□> NEEDLE, 140 ASSY	
17	118064001	1	<012-□, 013-□, 014-□, 015-□> 6カクボウスパナ4	<012-□, 013-□, 014-□, 015-□> HEXAGONAL WRENCH, 4	
21	107780001	1	<□/RP1> スハナ10X12	<□/RP1> WRENCH, 10X12	
71	S09021100	1	グリス	GREASE	
12	107779001	1	<オプションパーツ (フィーディングフット用)> スハナ6X7	<OPTION PARTS (FOR FEEDING PRESSER FOOT)> WRENCH, 6X7	
22	147893009	1	<オプションパーツ> オサエアゲフミイタ	<OPTION PARTS> TREADLE PEDAL	
23	021400106	2	ナツト1シユ4	NUT, 1 M4	
24	062401406	2	ナベコ4X14	SCREW, PAN M4X14	
25	116016001	2	ヘタルトメ	PEDAL STOPPER	

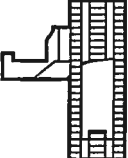
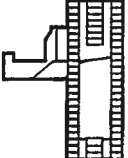
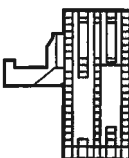
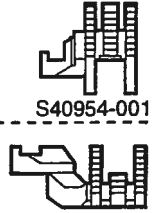
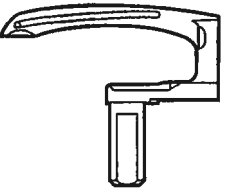

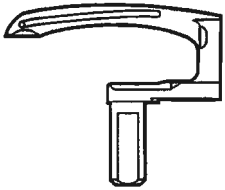

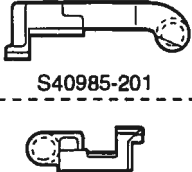





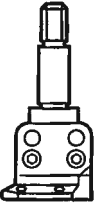
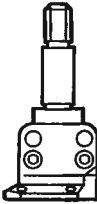
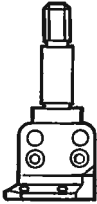
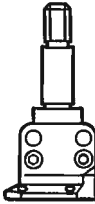
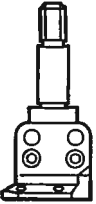
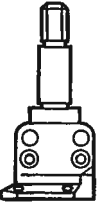







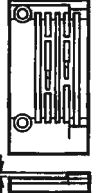



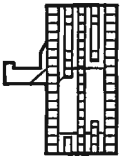
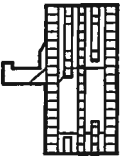
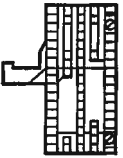
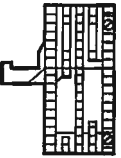
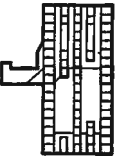
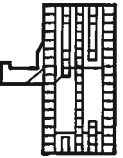









Ga1 . ゲージ部品一覧表 / Gauge parts List / Lehrenliste / Liste des Pièces de cartment / Lista d'ePiezas de calibradores



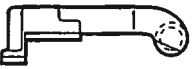
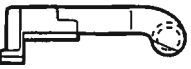
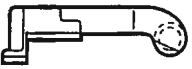
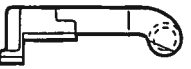
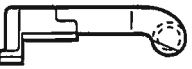









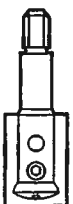
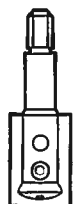
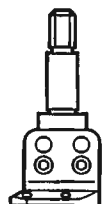
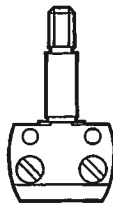
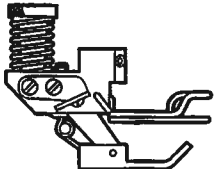
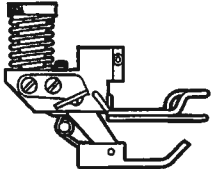



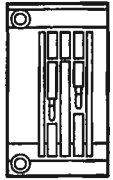
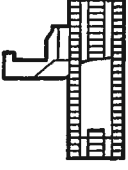
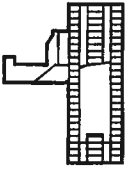
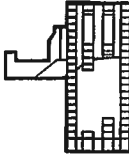
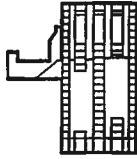
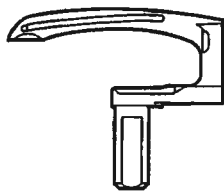
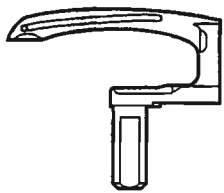

針数 No. of needles  
仕様 Specifications  
送り方式 Feed method  
装置 Devices

仕様 Specifications	012-0	012-T	012-5	0D2-0
仕様ラベル Label	S28933-003	S28933-004	S28933-005	S28933-006
用途 Application	中厚・地縫用 Plain Stitching	中厚・地縫用 Plain Stitching	中厚・タコ巻縫用 Binding Stitching	中厚・地縫用 Plain Stitching
針数(本) No. of Needles	1	2	2	1
針巾(mm) Needle Spacing(mm)	—	0.4	6.4	—
針止メ組 Needle Clamp Assembly	 S17480-101	 S40962-001	 S40987-101	 S17480-101
押工組 Presser Foot Assembly	 S40541-101	 S40969-101	 S40990-201	 S40952-101
針板 Needle Plate	 S40538-001	 S40964-001	 S40989-001	 S40538-001
送り歯 Feed Dog	 S40565-001	 S40972-001	 S40995-001	 S40954-001 S40955-001
ルーパ Looper	 S40569-001	 S40973-001 S40974-001	 S40973-001 S40974-001	 S40569-001
ハリウケ Needle Guard	 S08756-001	 S40967-001	 S40985-201 S40986-001	 S08756-001

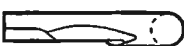



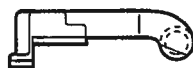





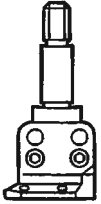
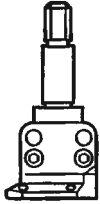
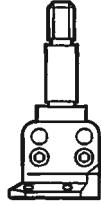
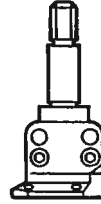





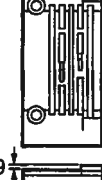
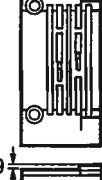
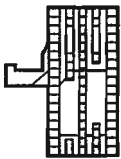
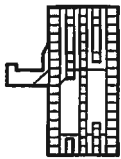
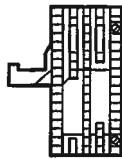
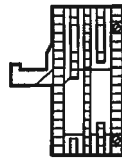



Ga2 . ゲージ部品一覧表 / Gauge parts List / Lehenliste / Liste des Pièces de cartment / Lista d'ePiezas de calibradores

013-5	013-6	014-5	014-6	015-5	015-6
S28933-008	S28933-009	S28933-010	S28933-011	S28933-013	S28933-014
厚物・タコ巻縫用 Heavy Materials	厚物・タコ巻縫用 Heavy Materials	厚物・タコ巻縫用 Heavy Materials	厚物・タコ巻縫用 Heavy Materials	厚物・逆タコ巻縫用 Heavy Materials	厚物・逆タコ巻縫用 Heavy Materials
2	2	2	2	2	2
6.4	7.2	6.4	7.2	6.4	7.2
 S40987-101	 S44880-001	 S40987-101	 S44880-001	 S40987-101	 S44880-001
 S44888-001	 S44892-001	 S44891-001	 S44894-001	 S48633-001	 S48636-001
 S44883-001	 S44885-001	 1.9 S44884-001	 1.9 S44886-001	 S44883-001	 S44885-001
 S44904-001	 S44904-001	 S44901-001	 S44901-001	 S44904-001	 S44904-001
 S40973-001	 S40973-001	 S40973-001	 S40973-001	 S40973-001	 S40973-001
 S40974-001	 S40974-001	 S40974-001	 S40974-001	 S40974-001	 S40974-001
 S40985-201	 S40985-201	 S40985-201	 S40985-201	 S40985-201	 S40985-201
 S40986-001	 S40986-001	 S40986-001	 S40986-001	 S40986-001	 S40986-001

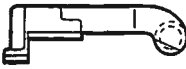
Ga3 . ゲージ部品一覧表 / Gauge parts List / Lehrenliste / Liste des Pièces de cartment  
 / Lista d'ePiezas de calibradores

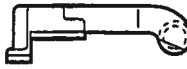
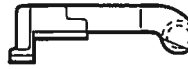
仕様 Specifications	for 012-0	for 012-0	for 012-5	for 012-5
仕様ラベル Label	Option	Option	Option	Option
用途 Application	地縫用 (薄物用フィーディングフット付) Plain Stitching (Thin W / Feeding Presser Foot)	地縫用 (中厚用フィーディングフット付) Plain Stitching (Medium Thick W / Feeding Presser Foot)	中厚・タコ巻縫用 Bindibg Stitching	中厚・タコ巻縫用 Bindibg Stitching
針数(本) No. of Needles	1	1	2	2
針巾(mm) Needle Spacing(mm)	—	—	4.8	9.5
針止メ組 Needle Clamp Assembly	 S17480-101	 S17480-101	 S47216-001	 S45085-001
押工組 Presser Foot Assembly	 S40548-001	 S40548-001	 S47219-001	 S45090-001
針板 Needle Plate	 S40538-001	 S40538-001	 S47218-001	 S45087-001
送り歯 Feed Dog	 S40564-001 (細目) (EXTRA FINE FEED DOG)	 S40565-001	 S47221-001	 S45092-001
ルーパ Looper	 S40569-001	 S40569-001	 S40973-001  S40974-001	 S40973-001  S40974-001
ハリウケ Needle Guard	 S08756-001	 S08756-001	 S40985-201  S40986-001	 S40985-201  S45089-001

Ga4 . ゲージ部品一覧表 / Gauge parts List / Lehrenliste / Liste des Pièces de cartment / Lista d'ePiezas de calibradores

for 013-5	for 013-6	for 014-5	for 014-6
Option	Option	Option	Option
厚物・タコ巻縫用 空環対応 Heavy Materials	厚物・タコ巻縫用 空環対応 Heavy Materials	厚物・タコ巻縫用 空環対応 Heavy Materials	厚物・タコ巻縫用 空環対応 Heavy Materials
2	2	2	2
6.4	7.2	6.4	7.2
 S40987-101	 S44880-001	 S40987-101	 S44880-001
 S48638-001	 S48641-001	 S48639-001	 S48642-001
 S44883-001	 S44885-001	 1.9 S44884-001	 1.9 S44886-001
 S44904-001	 S44904-001	 S44901-001	 S44901-001
 S40973-001	 S40973-001	 S40973-001	 S40973-001
 S40974-001	 S40974-001	 S40974-001	 S40974-001
 S40985-201	 S40985-201	 S40985-201	 S40985-201
 S40986-001	 S40986-001	 S40986-001	 S40986-001



索引 / INDEX / VERZEICHNIS  
/ INDEX / INDICE

CODE	REF.NO.	Page
S00017001	A - 102	2
S00075000	A - 90-3	2
S00313009	A - 24	2
	A - 123	4
S00356001	L - 51	40
S00383001	L - 52	40
S00879001	E - 25	20
S01295001	E - 40-7-3	24
	E - 40-18-3	24
S01943001	Z - 6	46
S02556001	G - 33	30
S02606000	A - 5	2
S02775001	Z - 90-1-4	46
	Z - 90-2-4	48
S02778002	Z - 90-1-13	46
	Z - 90-2-13	48
S02786002	Z - 90-1-14	46
	Z - 90-2-14	48
S03704002	B - 50	12
	F - 46	26
	J - 28	36
S04109001	Z - 90-1-5	46
	Z - 90-2-5	48
S06701000	Z - 19	46
S06704001	Z - 40	46
S07317001	A - 90-6	2
S08467000	F - 70	26
S08627001	A - 2-1	6
	A - 2-1	6
	A - 2-1	6
	A - 2-1	8
	A - 2-1	8
	A - 2-1	10
	A - 2-1	10
S08628000	A - 3	2
S08631000	A - 16	2
S08633101	A - 26	2
S08634151	A - 30-1	6
	A - 30-1	8
S08637001	A - 33-1	6
	A - 33-1	6
	A - 33-1	6
	A - 33-1	8
	A - 33-1	8
	A - 33-1	10
	A - 33-1	10
S08639000	A - 35-1	6
	A - 35-1	6
	A - 35-1	6
	A - 35-1	8
	A - 35-1	10
S08640001	A - 36-1	6
	A - 36-1	6
	A - 36-1	6
	A - 36-1	8
S08642001	A - 38	2
S08646100	A - 40	2
S08647101	A - 41-1	6
	A - 41-1	6
	A - 41-1	6
	A - 41-1	8
S08651001	A - 42	2
S08652000	A - 43	2

CODE	REF.NO.	Page
S08653001	A - 48	2
S08665001	A - 100	2
S08667001	A - 105	2
S08668001	A - 108	2
S08670000	A - 116	4
S08671101	A - 119	4
S08672000	A - 120	4
S08673000	A - 124	8
	A - 128	4
S08674000	A - 138	4
S08675000	A - 139	4
S08682001	B - 3	12
S08683000	B - 4	12
S08684101	B - 6	12
S08685001	B - 6-1	12
S08686101	B - 6-2	12
S08687001	B - 8-1	14
	B - 8-1	14
	B - 8-1	14
	B - 8-1	16
S08688051	B - 9	12
S08689001	B - 11-1	14
	B - 11-1	14
	B - 11-1	16
S08692101	B - 16	12
S08693001	B - 16-1	12
S08694001	B - 16-2	12
S08695001	B - 16-4-1	12
S08696000	B - 23	12
S08697000	B - 24	12
S08698001	B - 25	12
S08715016	B - 31	14
	B - 31	14
	B - 31	16
S08715021	B - 31	14
	B - 31	14
S08715022	B - 31	14
	B - 31	16
S08715116	Z - 1	48
S08715121	Z - 1	48
S08715122	Z - 1	48
S08716301	B - 35-1	14
	B - 35-1	14
	B - 35-1	16
S08750001	B - 42	12
S08751001	B - 44	12
S08752001	B - 46	12
S08753000	B - 48	12
S08754000	B - 49	12
	J - 27	36
S08755101	B - 51	12
S08756001	B - 53-1	14
S08758109	C - 1	18
S08760009	C - 1-1	18
S08761100	C - 3	18
S08767001	E - 1	20
S08768001	E - 2	20
S08769001	E - 6	20
S08770000	E - 12	20
	J - 7	36
	L - 49	40
S08771001	E - 14	20

CODE	REF.NO.	Page
S08774001	E - 18-1	22
	E - 18-1	22
S08775000	E - 28	20
S08776001	E - 30	20
S08777001	E - 31	20
S08870001	F - 8	26
S08871001	F - 10	26
S08872001	F - 20-2	28
S08873001	F - 20-2-1	28
S08876000	F - 36	26
S08877001	F - 44	26
S08878001	F - 54	28
S08879001	F - 57	28
S08880001	F - 58	28
S08881101	F - 64	28
S08889101	H - 1	34
S08890001	H - 1-1	34
S08891001	H - 5	34
S08892001	H - 8	34
S08895002	H - 10	34
S08896101	H - 11	34
S08897001	H - 11-1	34
S08898000	H - 13	34
S08899001	H - 14	34
S08900000	H - 16	34
S08903000	H - 17	34
S08904000	H - 20	34
S08911000	J - 8	36
S08912001	J - 10-1	36
S08914001	J - 20	36
S08915001	J - 23	36
S08917000	J - 26	36
S08918001	J - 29	36
S08919001	J - 32	36
S08920001	J - 33	36
S08921101	J - 35	36
S08935001	K - 1	38
S08936201	K - 3	38
S08937101	K - 3-4	38
S08939100	K - 3-6	38
S08940000	K - 6	38
S08943000	K - 12	38
S08944001	K - 13	38
S08945001	K - 16	38
S08946000	K - 18	38
S08948001	K - 22	38
S08951001	K - 26	38
S08953001	K - 37	38
S08955051	K - 32	38
S08956100	K - 34	38
S08957001	K - 35	38
S08958001	K - 40	38
S08961101	L - 1	40
S08962109	L - 7	40
S08963001	L - 10-1	42
	L - 10-2	42
	L - 10-2	42
S08964001	L - 11-1	42
	L - 11-2	42
	L - 11-2	42
S08965009	L - 27	40
S08966001	L - 28	40
S08967001	H - 19	34

索引 / INDEX / VERZEICHNIS  
/ INDEX / INDICE

CODE	REF.NO.	Page
S08967001	L - 29	40
S08968001	L - 31	40
S08969201	L - 40	40
S08970001	L - 91-1	42
S08971201	L - 45	40
S08976001	L - 50	40
S08977001	L - 54	40
S08978001	L - 57	40
S08981001	L - 68	40
S08982001	L - 70-1	42
	L - 70-1	42
	L - 70-1	44
S08983001	L - 72	40
S08984001	L - 73-2	44
S08987001	L - 104	40
S08992001	L - 102	40
S08993101	L - 108	40
S08994001	L - 111	40
S09001101	Z - 36	46
S09002009	Z - 43	46
S09021100	Z - 71	48
S09039001	G - 36-2	30
S09120001	B - 16-3	12
S09121001	B - 41	12
S09123101	A - 34	2
S09124001	B - 38	12
S09125001	K - 45	38
S09251001	J - 35-1	36
S09316000	K - 42	38
S10774001	A - 14	2
S11561001	Z - 130	46
S11562001	Z - 131	46
S11588001	J - 25-1	36
S11589000	J - 37	36
S12703001	A - 2-2	8
S12724001	B - 8-2	14
	B - 8-2	16
S12725101	B - 11-2	14
	B - 11-2	14
	B - 11-2	14
	B - 11-2	16
S12821001	G - 1-4	30
S12858000	G - 46-1	32
S12882001	L - 91-2	42
	L - 91-2	44
	L - 93	42
	L - 93	44
	L - 113-2	42
	L - 113-2	44
	L - 125-2	42
	L - 125-2	44
	L - 128	40
S12900001	G - 36-5	30
S12913201	G - 1-1	30
S12915001	G - 1-2	30
S12916001	G - 1-3	30
S12918000	G - 14	30
S12919001	G - 16	30
S12920001	G - 18	30
S12921001	G - 19	30
S12922001	G - 20	30
S12923001	G - 22	30
S12924001	G - 26	30

CODE	REF.NO.	Page
S12933001	G - 32	30
S12934101	G - 36	30
S12936001	G - 37	30
S12937101	G - 39	30
S12939001	G - 43	30
S12942001	G - 49	32
S12943001	G - 51	32
S12946001	G - 59	32
S13085001	E - 40-3-6	22
S13385001	B - 39	12
S13414201	G - 1	30
S13415101	G - 36-1	30
S14621001	B - 1-2	12
S14622001	H - 1-2	34
S14623001	H - 11-2	34
S16249001	F - 80	26
S16498001	F - 1-1	26
S17773001	G - 2	30
S18530001	L - 94	40
S18532001	L - 96	40
S18534001	L - 98	40
S18535001	L - 100	40
S18947001	E - 21-2	22
	E - 21-2	22
S20118151	E - 40-1-2	22
	E - 40-2-2	22
	E - 40-3-12	22
	E - 40-7-15	24
	E - 40-18-10	24
S21798001	Z - 90-1-10	46
	Z - 90-2-10	48
S23359001	F - 22	28
	F - 27	26
S25818051	L - 129	40
S28007001	A - 68	8
S28008000	A - 69	8
S28250001	G - 6	30
S28252000	G - 6-2	30
S28253001	G - 11	30
S28254001	G - 28	30
S28256001	G - 29	30
S28261101	G - 46	32
S28263001	G - 52	32
S28264001	G - 53	32
S28265001	G - 66	32
S28266001	G - 68	32
S28333001	G - 61	32
S28334001	G - 41	30
S28438001	L - 73-1	40
S28802001	A - 90	2
S28803001	A - 90-1	2
S28804001	A - 90-2	2
S28809201	A - 20	2
S28810051	A - 15	2
S28957001	B - 1	12
S28958001	B - 1-1	12
S29854109	Z - 90-2	48
S30086001	B - 16-4	12
S30564000	L - 17-1	42
	L - 17-2	42
	L - 17-2	44
S30565002	L - 22	42
	L - 22	44

CODE	REF.NO.	Page
S30565002	L - 24	42
	L - 24	44
S30565003	L - 21	42
	L - 21	42
	L - 21	44
	L - 23	42
	L - 23	42
	L - 23	44
S31012001	E - 19	20
S31013001	E - 20	20
S34200000	A - 81	6
	A - 81	6
	A - 81	6
	A - 81	8
	A - 81	10
S36894000	E - 40-3-14	22
S37037001	Z - 90-1-15-3	46
	Z - 90-1-16-3	46
	Z - 90-2-15-3	48
	Z - 90-2-16-3	48
	Z - 90-2-17-3	48
S37038001	Z - 90-1-15-2	46
	Z - 90-2-15-2	48
	Z - 90-2-16-2	48
S37818001	D - 10-7	18
S38648001	Z - 90-1-4-2	46
	Z - 90-2-4-2	48
S39086001	F - 34	26
S40358101	E - 40-2-5	22
S40360001	E - 40-2-7	22
S40374001	E - 40-2-9	22
S40532101	A - 12	2
S40533001	A - 115	4
S40535001	A - 65	6
	A - 65	6
	A - 65	8
S40539001	E - 35	22
S40544101	E - 40-3-2	22
S40546001	E - 40-1-4	22
S40549101	E - 40-3-1	22
S40555001	E - 40-3-3	22
S40556001	E - 40-3-4	22
S40557001	E - 40-3-10	22
S40558001	E - 40-3-9	22
S40559001	F - 47	28
S40562001	F - 20-1	28
S40567001	J - 1	36
S40569001	J - 14-1	36
S40570001	L - 120	40
S40571001	L - 122-1	42
	L - 122-1	44
	L - 122-2	42
S40572001	L - 116	40
S40574009	Z - 90-1	46
S40640001	Z - 90-1-7	46
	Z - 90-2-7	48
S40641001	Z - 90-1-15	46
	Z - 90-2-15	48
S40642001	Z - 90-2-16	48
S40643001	Z - 90-1-16	46
	Z - 90-2-17	48
S40960051	A - 30-2	6
	A - 30-2	6

索引 / INDEX / VERZEICHNIS  
/ INDEX / INDICE

CODE	REF.NO.	Page
S40960051	A - 30-2	8
	A - 30-2	8
	A - 30-2	10
S40961001	A - 32	6
	A - 32	6
	A - 32	8
	A - 32	8
	A - 32	10
	A - 32	10
S40965001	B - 55	14
	B - 55	14
	B - 55	14
	B - 55	16
	B - 55	16
S40966001	B - 58	14
	B - 58	14
	B - 58	14
	B - 58	16
	B - 58	16
S40967001	B - 53-2	14
S40973001	J - 14-2	36
	J - 14-2	36
S40974001	J - 14-3	36
	J - 14-3	36
S40975001	J - 10-3	36
	J - 10-3	36
S40976001	J - 10-2	36
	J - 10-2	36
S40977001	J - 5	36
S40985201	B - 53-3	14
	B - 53-3	14
	B - 53-3	14
	B - 53-3	16
	B - 53-3	16
S40986101	B - 60-3	14
	B - 60-3	14
	B - 60-3	16
	B - 60-3	16
	B - 60-3	16
S40996001	J - 16	36
S44875001	A - 33-4	8
S44876001	A - 36-4	8
	A - 36-4	8
	A - 36-4	10
	A - 36-4	10
S44877101	A - 71	8
S44878101	A - 41-4	8
	A - 41-4	8
	A - 41-4	10
S44879001	A - 73	8
	A - 73	8
	A - 73	10
S44882001	B - 35-3	14
	B - 35-3	14
	B - 35-3	14
	B - 35-3	16
S44887001	E - 18-2	24
	E - 18-2	24
S44902001	F - 75-1-1	28
S44903001	F - 75-1-2	28
S44906101	G - 44	32
S44907001	G - 100	32
S44911001	L - 70-2	42

CODE	REF.NO.	Page
S44912000	D - 10-8	18
S45089001	B - 60-4	16
S47181001	A - 41-6	10
S47182001	A - 73-3	10
S47932001	E - 40-1-5	22
S48628001	A - 30-3	10
S48629000	A - 75	10
S48630001	D - 10-9	18
S49420001	D - 10-10	18
014060632	Z - 90-1-16-1	46
	Z - 90-2-17-1	48
014680422	B - 54	12
	B - 57	14
	B - 57	14
	B - 57	14
	B - 57	16
	B - 57	16
	B - 59	14
	B - 59	14
	B - 59	16
	B - 59	16
	E - 40-3-11	22
	G - 13	30
	G - 67	32
	J - 15-1	36
	J - 15-2	36
	J - 15-2	36
	L - 5	42
	L - 5	42
	L - 6	40
	L - 71	40
	L - 117	40
014680622	B - 43	12
	B - 45	12
	J - 21	36
014760622	K - 17	38
	B - 15	12
	B - 18-1	14
	B - 18-1	14
	B - 18-1	16
	E - 26	20
	G - 1-1-4	30
	G - 50	32
014770622	B - 2	12
	B - 5	12
	B - 7	12
	B - 13	12
	B - 50-1	12
	F - 46-1	26
	F - 47-1	28
	G - 3	30
	G - 54	32
	H - 9	34
	H - 12	34
	H - 15	34
	J - 24	36
	J - 28-1	36
	K - 2	38
	L - 45-1	40
014780622	F - 43	26
	H - 2	34
017681012	G - 69	32

CODE	REF.NO.	Page
017781412	F - 67	28
	K - 4	38
018060822	A - 13	2
018061622	G - 17	30
	G - 47	32
018063022	G - 7	30
018081622	A - 140	4
018401422	L - 45-2	40
018501022	F - 71-1	28
018680822	L - 41	40
	L - 97	40
018681022	B - 36	12
	B - 37-2	14
	B - 37-2	16
	B - 52	12
018771432	E - 10	20
	F - 7	26
	F - 48	28
	F - 50	28
	F - 54-2	28
	F - 57-1	28
	G - 2-1	30
	H - 7	34
	J - 2	36
	J - 12-1	36
	J - 12-2	36
	J - 12-2	36
	L - 47	40
	L - 55	40
021080106	Z - 135	46
021400106	Z - 23	48
021500106	Z - 90-1-10-3	46
	Z - 90-1-15-1	46
	Z - 90-1-16-2	46
	Z - 90-2-10-3	48
	Z - 90-2-15-1	48
	Z - 90-2-16-1	48
	Z - 90-2-17-2	48
021670102	G - 106	32
021670202	E - 40-3-7	22
025030232	A - 90-5	2
025050232	A - 90-8	2
025080132	A - 35-2	8
	A - 35-2	8
	A - 35-2	10
025080336	Z - 133	46
025350332	K - 3-2	38
025680133	A - 83	2
025770232	F - 66	28
028050246	A - 90-7	2
	Z - 90-1-10-2	46
	Z - 90-2-10-2	48
028080242	Z - 134	46
032461606	Z - 136	46
047200642	C - 1-2	18
047401442	G - 65	32
047502242	F - 63	28
048040342	F - 9	26
048090142	G - 30	30
048150143	F - 1-12	26
060660416	L - 112	40
060670512	A - 90-10	2
060670812	L - 121	40

索引 / INDEX / VERZEICHNIS  
/ INDEX / INDICE

CODE	REF.NO.	Page
060680512	F -81	26
060680712	A -91	2
	A -106	2
	E -3	20
	L -95	40
060681612	A -45	2
062350612	L -130	40
062401406	Z -24	48
062501406	Z -90-1-15-4	46
	Z -90-2-15-4	48
062630612	E -40-1-3	22
	G -1-5	30
	J -34	36
062660412	J -4	36
062660512	A -90-4	2
	E -40-7-10	24
	F -1-8	26
062660712	F -54-1	28
062670412	E -40-2-3	22
	E -40-3-13	22
	E -40-7-16	24
	E -40-18-11	24
062670512	L -99	40
	L -109	40
	L -126	40
062670612	A -136	4
	B -21	12
	K -8	38
	K -10	38
	K -14	38
	K -23	38
	K -41	38
	K -51	38
	L -69	40
	L -123-1	42
	L -123-1	44
	L -123-2	42
062670812	F -19	26
	H -25	34
	K -3-3	38
062671012	B -56	14
	B -56	14
	B -56	14
	B -56	16
	B -56	16
	K -3-8	38
062671212	E -40-1-1	22
062680612	A -47	2
	G -45	32
	H -4	34
	L -92	40
062680812	A -27	6
	A -27	8
	A -70	8
	A -76	10
	A -101	2
	B -37-1	14
	B -37-1	14
	B -37-1	14
	B -37-1	14
	B -37-1	16
	K -33	38
	K -43	38

CODE	REF.NO.	Page
062680812	L -2	40
	L -74	40
062681012	A -4	2
	A -21	2
	A -28	6
	A -28	6
	A -28	8
	A -28	8
	A -28	10
	A -28	10
	A -111	4
	F -31	26
	F -35	26
	L -8	40
	L -58	40
062681212	L -32	40
062681412	A -51	2
	E -29	20
062681612	A -17	2
062682012	G -55	32
062710812	A -66	6
	A -66	6
	A -66	6
	A -66	8
	A -66	8
	A -66	8
	A -66	10
062711012	A -78	10
	B -10	12
062780812	K -46	38
072600000	H -22	34
081003670	F -12	26
081014670	A -6	2
081032870	H -18	34
081044070	K -36	38
081046870	B -26	14
	B -26	14
	B -26	14
	B -26	16
087311215	C -2	18
100025002	F -1-17	26
100032004	A -31	2
100064005	B -16-4-2	12
	E -40-2-1	22
	E -40-7-14	24
	E -40-18-9	24
100251001	F -5	26
100257010	G -105	32
100294002	F -61	28
100526003	G -26-1	30
100645003	A -80	2
	E -38	22
	F -30	26
	K -44	38
	L -39	40
	L -59	40
100666002	Z -132	46
101572101	Z -4	46
101706001	A -104-1	2
	F -40	26
102424004	Z -44	46
102538002	G -101	32
102571003	E -37	22

CODE	REF.NO.	Page
102630001	B -22	12
104449009	A -22	2
104450109	A -60	8
	A -130	4
104464001	B -12	12
105161004	E -40-3-8	22
	G -1-1-3	30
	L -110	40
	L -115	40
	L -124-1	42
	L -124-1	44
	L -124-2	42
	L -127	40
105234003	A -52	2
	A -112	4
	G -56	32
105343001	Z -13	46
105812003	G -35	30
106128004	G -38	30
	G -42	30
106129001	A -90-9	2
106588003	G -64	32
107153001	B -17	12
	G -34	30
107272002	F -45	26
	G -31	30
107407003	A -109	4
	A -117-1	6
	A -117-1	6
	A -117-1	6
	A -117-1	8
	A -117-1	8
	A -117-1	10
	A -117-1	10
	A -117-2	8
	A -121-1	6
	A -121-1	6
	A -121-1	6
	A -121-1	8
	A -121-1	8
	A -121-1	10
	A -121-1	10
	A -121-2	8
107453001	G -24	30
107779001	Z -12	48
107780001	Z -21	48
108520009	A -23	6
	A -23	6
	A -23	6
	A -23	8
	A -23	8
	A -23	10
	A -23	10
108960002	A -72	8
	A -74	8
	A -74	8
	A -74	10
	A -74	10
109203001	A -142	4
	F -62	28
109239001	G -60	32
110140001	G -25	30
	G -27	30

索引 / INDEX / VERZEICHNIS  
/ INDEX / INDICE

CODE	REF.NO.	Page
110161006	J -31	36
110167001	G -57	32
110168001	G -58	32
110641002	A -141	4
110704001	J -3	36
110793001	E -7	20
110813001	L -12-1	42
	L -12-2	42
	L -12-2	42
110832009	L -14-1	42
	L -14-2	42
	L -14-2	42
111105002	E -40-2-6	22
	E -40-3-5	22
	E -40-7-12	24
	E -40-18-7	24
112299001	L -76	44
112300001	L -75	44
112301001	L -77	44
112351001	K -27	38
112359052	K -30	38
	K -38	38
	K -38	38
112364001	K -24	38
112467002	K -3-11	38
112700001	G -63	32
112743001	K -7	38
112754001	K -53	38
113431002	F -52	28
113644001	G -1-1-1	30
113880001	D -10-3	18
114294001	H -21	34
114985001	A -46	2
115834001	D -10-2	18
115904001	L -78	44
116016001	Z -25	48
117466000	Z -18	46
117516001	A -122-1	6
	A -122-1	6
	A -122-1	6
	A -122-1	8
	A -122-1	8
	A -122-1	10
	A -122-1	10
	A -122-2	8
	A -126	8
	E -39	22
117517003	F -1-16	26
117608001	G -8	30
	G -48	32
117934009	A -19	2
118064001	Z -17	48
118718001	L -30	40
118770001	K -11	38
118837001	Z -5	46
118853001	B -14	12
	G -36-1-1	30
120990001	J -35-1-1	36
121007001	G -40	30
123185001	A -37	2
	A -39	2
126863001	Z -90-1-3	46
	Z -90-2-3	48
138843001	Z -90-1-12	46

CODE	REF.NO.	Page
138843001	Z -90-2-12	48
140063001	A -107	2
140092001	G -12	30
140165001	F -1-3	26
140176001	F -1-15	26
140205001	F -49	28
140207001	F -21	28
140209001	F -23	28
140210001	F -24	28
140217001	F -28	26
140313001	J -35-2	36
140326009	F -4	26
140327001	F -14	26
	J -9	36
140407001	E -22	20
	E -34	22
	E -34	22
140759000	Z -41	46
141183000	A -103	2
141208001	E -23	20
141728001	E -21-1	22
	E -21-1	24
	E -21-1	24
142274009	A -49	2
142359001	K -5	38
142721001	Z -8	46
142997001	Z -90-1-6	46
142998101	Z -90-2-6	48
143311001	H -23	34
143312000	H -24	34
143325001	E -5	20
143564001	F -51	28
143565001	F -53	28
143602001	L -42	40
144053001	F -1-9	26
144055001	F -1-10	26
144075001	G -1-1-2	30
	L -114	40
144103009	L -15-1	42
	L -15-2	42
	L -15-2	44
144104001	L -18-1	42
	L -18-2	42
	L -18-2	44
144110001	L -19-1	42
	L -19-2	42
	L -19-2	44
144224001	Z -42	46
144504001	L -105	40
144505000	L -106	40
144619000	K -3-1	38
144622001	K -3-5	38
144875001	K -3-9	38
144876001	K -3-10	38
145277205	Z -20	46
145446001	L -16-1	42
	L -16-2	42
	L -16-2	44
145472001	E -24	20
145663001	F -1-2	26
145688000	B -20	12
145737001	K -21	38
146049001	Z -7	46





CODE	REF.NO.	Page
146315009	A -125	4
146354001	A -67	6
	A -67	6
	A -67	6
	A -67	8
	A -67	8
	A -67	8
	A -67	10
	A -67	10
	A -77	10
	A -79	10
146401001	F -1-4	26
146402001	F -1-5	26
146403001	F -1-6	26
146404001	F -1-7	26
146457001	A -135	4
146528102	F -1	26
146529001	F -1-11	26
146530001	F -1-13	26
146531001	F -1-14	26
146532001	F -2	26
146533001	F -6	26
146538101	F -13	26
146539000	F -15	26
146540000	F -16	26
146544000	F -20-1-1	28
	F -20-2-2	28
146547000	F -41	26
146548101	F -42	26
146554001	F -25	26
146555001	F -26	26
146556001	F -55	28
146559001	F -59	28
146560101	F -60	28
146563001	F -65	28
146586009	A -50	2
	A -110	4
	A -129	4
146624101	J -22	36
146741000	F -39	26
146924000	L -96-1	40
147318000	F -3	26
147363000	K -48	38
147527000	K -3-7	38
147528100	K -3-12	38
147529000	K -3-13	38
147871001	E -40-2-4	22
	E -40-7-1	24
	E -40-18-1	24
147872001	E -40-7-2	24
	E -40-18-2	24
147875001	E -40-7-6	24
	E -40-18-6	24
147876001	E -40-7-7	24
147877001	E -40-7-8	24
147878001	E -40-7-9	24
147879001	E -40-7-11	24
147880001	F -75-1-3	28
147890001	E -40-7-4	24
	E -40-18-4	24
147893009	Z -22	48
147919051	Z -35	46
147932001	E -40-2-8	22
	E -40-7-5	24

索引 / INDEX / VERZEICHNIS  
/ INDEX / INDICE

CODE	REF.NO.	Page
147932001	E -40-18-5	24
148084001	A -29	2
148120000	G -6-1	30
148294001	G -21	30
148372001	E -4	20
148425001	J -1-1	36
	J -22-1	36
148834001	F -56	28
148847001	J -30	36
148851001	L -18-3	42
149247001	Z -26	46
150173003	Z -90-1-9	46
	Z -90-2-9	48
150174000	Z -90-1-7-1	46
	Z -90-2-7-1	48
150179002	Z -90-1-10-1	46
	Z -90-2-10-1	48
150180001	Z -90-1-1	46
	Z -90-2-1	48
150182000	Z -90-1-2	46
	Z -90-2-2	48
150185009	Z -90-1-11	46
	Z -90-2-11	48
150206002	Z -90-1-4-1	46
	Z -90-2-4-1	48
150335001	Z -10	46
150604101	G -36-3	30
150605001	G -36-4	30
150644009	L -3	42
	L -3	42
150645009	L -4	40
151059001	A -137	4
151267001	A -118	4
151429001	K -9	38
151572101	E -40-7-13	24
	E -40-18-8	24
151584001	D -10-5	18
151927001	K -52	38
152718001	B -18-2	14
	B -18-2	14
	B -18-2	14
	B -18-2	16
153484001	F -11	26
153675001	A -44	2
153734001	H -3	34
154574001	E -36	22
154596000	E -27	20
154841009	A -61	8
	A -63	8
154886001	H -6	34
154956001	E -9	20
154957001	E -11	20
154965001	F -71-2	28
	L -101	40
	L -103	40
155144001	F -17	26
155145000	F -18	26
155151000	F -29	26
155162001	J -13	36
	J -13	36
	L -56	40
155175051	F -68	28
155176001	F -69	28

CODE	REF.NO.	Page
155177100	F -32	26
155178001	F -33	26
155220000	E -8	20
	L -48	40
155282101	K -29	38
155294100	K -49	38
155295001	K -50	38
155313001	L -113-1	42
	L -125-1	42
155510001	L -107	40
155539000	B -47	12
	E -13	20
	J -6	36
	L -53	40
156112003	Z -90-1-8	46
	Z -90-2-8	48
156265001	G -23	30
156887001	A -64	8
157840000	K -15	38
158437009	A -25	6
	A -25	6
	A -25	6
	A -25	8
	A -25	8
	A -25	8
	A -25	10
	A -25	10
159093009	G -62	32
159150009	A -7	2
	A -62	8
	G -15	30
159476000	K -25	38
	K -28	38
	K -31	38
	K -39	38
159574101	L -13-1	42
	L -13-2	42
	L -13-2	42
183893001	A -104	2

Wa. 警告ラベル / Warning labels / Warnschilder / Etiquettes d'avertissement  
/ Etiquetas de advertencia

警告ラベル / Warning labels	品名 / Name of parts	Size(mm)	Code
	操作注意ラベル・和	40×64	S38350-001
	Label, operation Eng.	40×64	S38349-001
	矢印マーク Mark, arrow	10×30	S37058-001
	アースマーク Mark, grounding	φ 12	S37060-001

**brother**

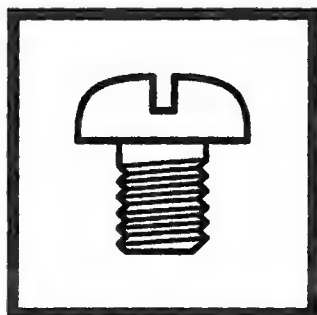

パーツブック  
PARTS BOOK  
TEILEKATALOG  
LIVRE DES PIECES  
LIBRO DE REFERENCIA DE PIEZAS

**ブラザー工業株式会社**

BROTHER INDUSTRIES, LTD.

〒467-8562 名古屋市瑞穂区河岸1丁目1番1号 TEL(052)824-2392

Printed in Japan / Gedrukt in Japan / Imprimé au Japon / Impreso en Japón

118-261  
S95261-201  
1999. 1 F ①

From the library of: Superior Sewing Machine & Supply LLC